

**MYPOOLDIRECT**  
*Swimming Pool & Enclosure European Distributor*

**UK SALES OFFICE: +44 (0) 1268 710425**

This manual contains the general and theoretical guidelines for the construction of the BLOKIT swimming pools.

These pools are in-ground and designed to be in the shapes and sizes given in this manual. It does not imply the responsibility of the designer.

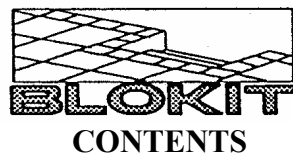

<b>Presentation</b>	<b>Page</b>	<b>3</b>
<b>Kit description</b>	<b>Page</b>	<b>5</b>
<b>Slab and screeding</b>	<b>Page</b>	<b>6</b>
<b>Concrete</b>	<b>Page</b>	<b>11</b>
<b>Installing the structure</b>	<b>Page</b>	<b>12</b>
<b>Placing the Pool fittings</b>	<b>Page</b>	<b>14</b>
<b>Pourring the wall</b>	<b>Page</b>	<b>15</b>
<b>Free-form pools</b>	<b>Page</b>	<b>18</b>
<b>Roman end steps</b>	<b>Page</b>	<b>21</b>
<b>Technical plans</b>	<b>Page</b>	<b>23</b>

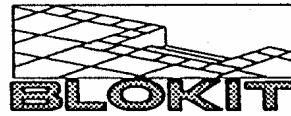

## GENERAL CHARACTERISTICS

BLOKIT is an original reinforced concrete swimming pool construction process. The shuttering system allows a swimming pool to be built up quickly and cleanly by building up high density expanded polystyrene blocks after placing a steel reinforcement.

This technique brings an additional insulating factor resulting in the gain of a few extra degrees. It also carries a 10 year manufacturer's guarantee.

### CHARACTERISTICS

The BLOKIT system consists of 2 basic expanded high density polystyrene modules, which are stable to ageing and to rot :

FIRST MODULE: length 1,50m, width 0,25m, height 0,27m, including 2 vertical walls 4,5cm thick joined by cross-pieces ( see dia.1).

The upper and lower sides have pins and holes which allow the blocks to fit together when placed one on top of the other.

At the ends, at the top and at the bottom of the block, outcuts allow semi-circular stoppers to be placed in order to transform a standard module into a corner module.

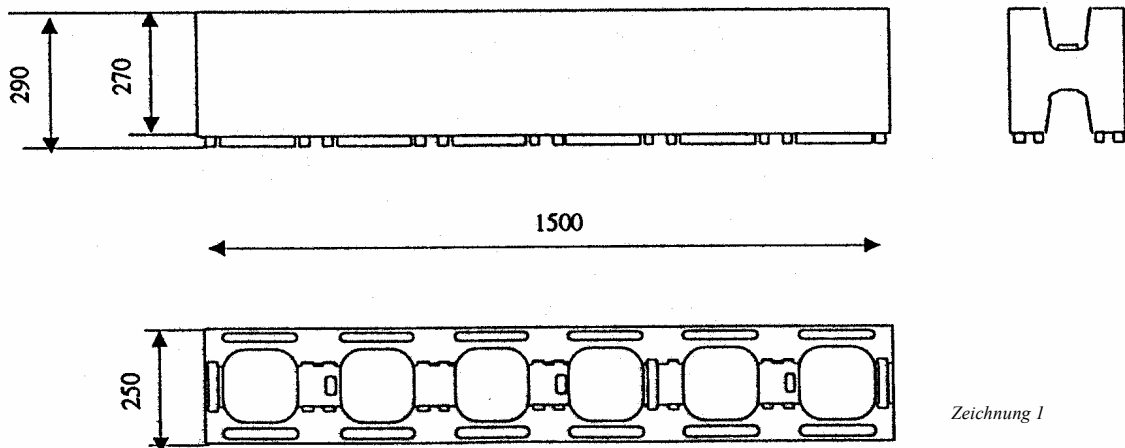

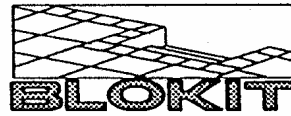

SECOND MODULE: length 0,50m, width 0,25m, height 0,27m with the same characteristics as the first module, except that only one end can be fitted with a stopper, the other already being filled.

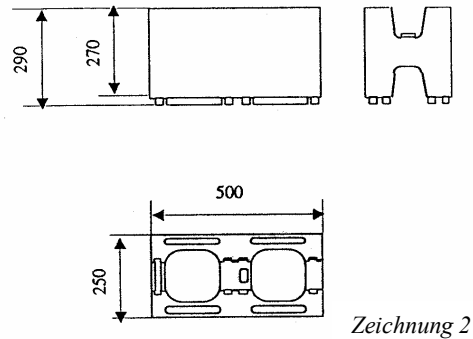

#### NOTE

Dimensional stability of polystyrene is only obtained 3 weeks after leaving the factory.

One can, in fact, observe that, when a block comes out of the mould, there are a few extra mm ( 4 to 5mm ) on the length and width but never on the height, which disappears during this period.

Despite the precautions taken by the manufacturer, it is important to take this factor into consideration and to:

-Check the manufacturing date on the sticker

-Possibly check the length of the large module, which should be 1,50m.

On a technical level, not respecting this precaution could result in problems, particularly for free-form pools, which may be incompatible with the liner.

This system uses 125 litres of concrete with a 350 kg / m<sup>2</sup> mix per m<sup>2</sup> of wall.

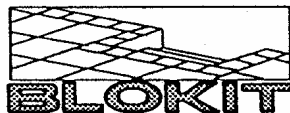

## PRESENTATION OF THE KIT

The kit includes:



-One set of blocks of the relevant sizes (1,50m or 0,50m) cut or not according to the type of pool chosen: Flat Based, Sloping Base, Hopper Base...

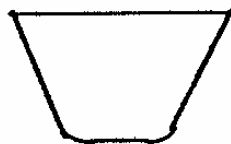

-One set of upper and lower stoppers.



-The special PVC Liner Lock and four corner pieces



-Expanded polystyrene triangular profile, to protect the four vertical corners of the pool

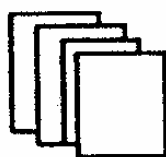

-A set of internal protection sheets, 50/100 thick, of the relevant sizes, to protect the inside of the structure against any damage

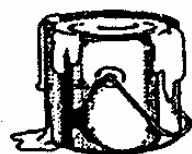

-Glue to place the internal and external protection sheets



-A roll of external protection sheeting to protect the outside of the blocks from any damage

NOTE : The quantities are shown on the technical plans

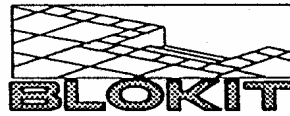

## SLAB & SCREEDING

### FLAT BASED POOL

On the bottom of the excavation,

-Place wooden boards around the edge with their height at the correct level for the top to correspond to the finished level of the slab

The boards should form a shuttering 0,50m larger than the dimensions of the pool to take into account the concrete support for the walls

### FIXING THE MAIN DRAIN

-Fix the pipe to the main drain

-Fix a 50mm Ø piece of pipe into the outside of the lower filled exit so as to block the main drain into the slab

-Protect the main drain with adhesive paper

-Fix the main drain and its pipe into the soil, making sure that the top is on level with the top of the slab, by using a level.

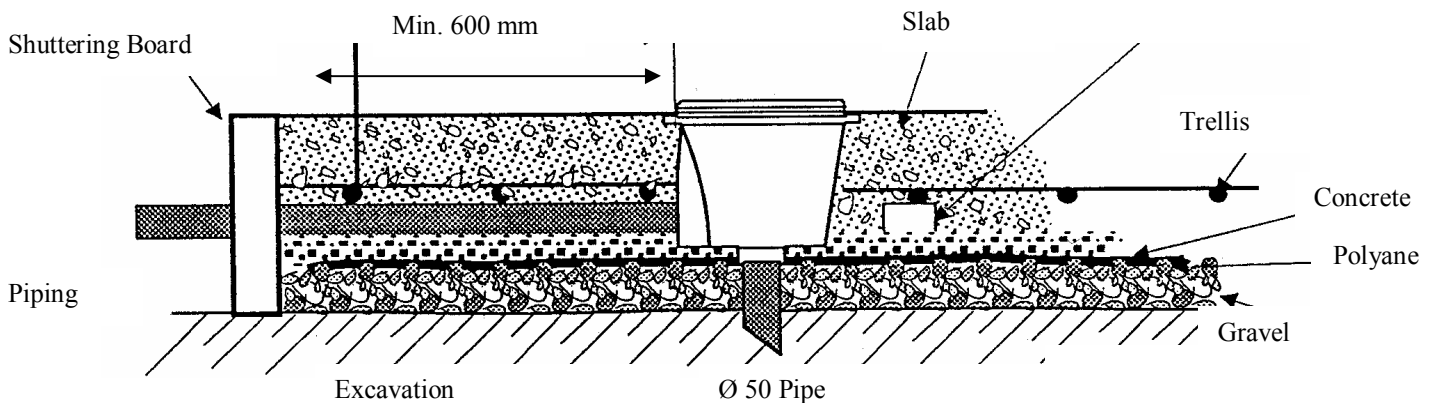

On the inside of the wooden shuttering, and over the whole surface, place the following underlay:

- \*Gravel of 0,05m thickness uniformly spread out
- \*Wide polyane sheeting
- \* 0,05m thick concrete over the whole base surface

These 3 stages need to be carried out in order to conform with the VERITAS approval guidelines

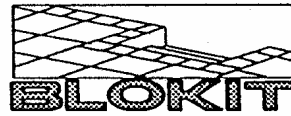

Place a welded steel trellis 150 x 150 x 4,5, making sure to outcut for the main drain.  
 The trellis should be overlapped by 20 to 30 cm and tied together.  
 The trellis should not rest on the concrete but on supports so that it is in the middle of the concrete slab when it is poured

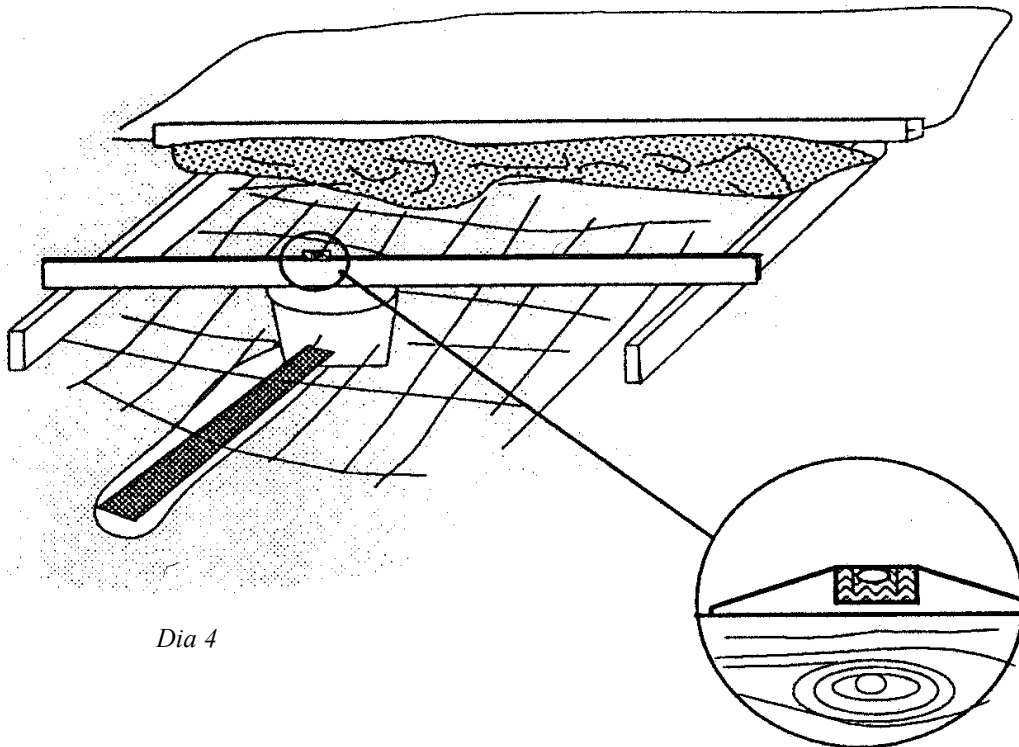

Dia 4

Position the vertical steels at 0,06m inside the internal edge of the wooden shuttering on the reference points previously marked out (see dia 5)

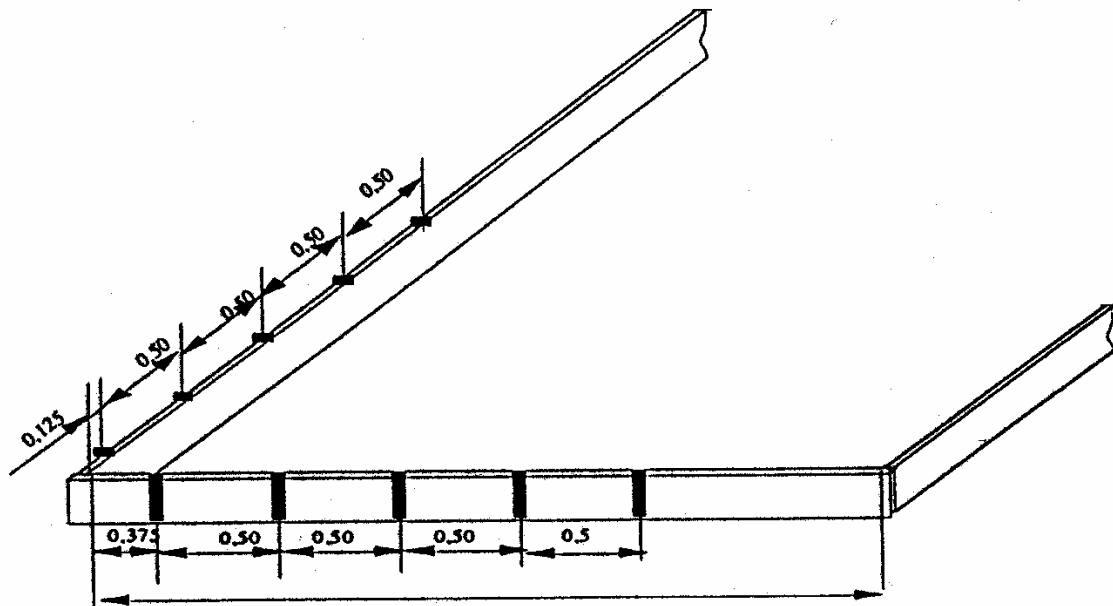

Dia. 5

- DEEP END OR "HOPPER BASED" POOLS

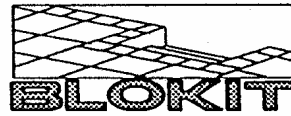

The concrete base of the pool will be built in two stages :

- 1) The shallow end and the surrounds
- 2) The deep end

#### 1) THE SHALLOW END AND SURROUNDS

- Place wooden shuttering at the top of the deep end descent
- Carry out the same stages as for a flat based pool ( see dia 6 )

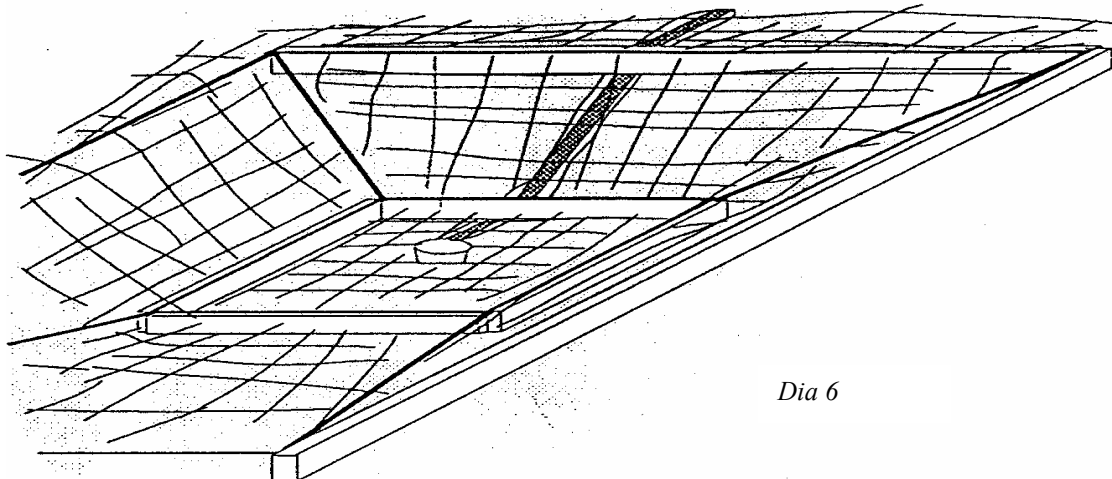

*Dia 6*

#### -2) THE HOPPER BASE

- Mark out the square at the base of the pool
- Check the dimensions of the deep end
- At the bottom of the four corners of the square EFGH ( see dia7 ) place 4 pegs or wooden shuttering planks marking out the exact shape, of which the top corresponds to the finished level of the slab.

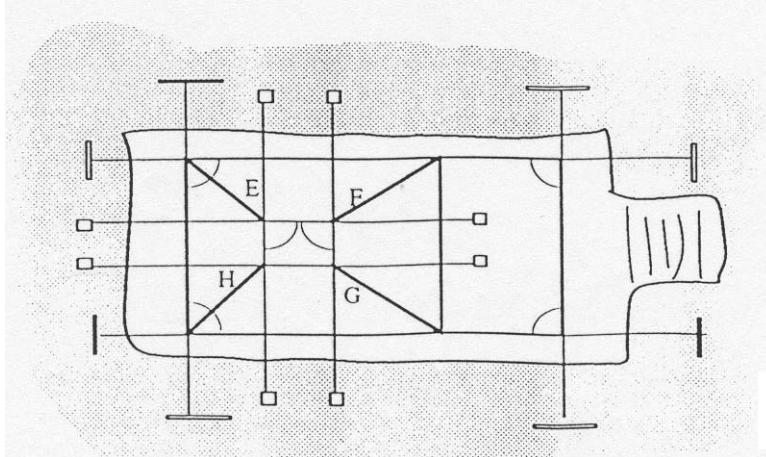

*Dia 7*

- Place the main drain pipe, bringing it up the hopper base side, on the side of the filter housing ( the pipe goes under the shuttering ). Until connecting it up, add 50cm of pipe on the outside of the shuttering boards.

- Connect up the main drain
- Place the underlay
- Place the steel trellis
- In order to ensure an equal thickness of concrete over the whole surface, place a few pegs to indicate the finished level of the concrete.

#### NOTE :

In order to make the BLOKIT installation easier, ensure that the surrounding edge is clean, smooth and level.



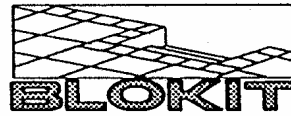

## CONCRETE

### POURING THE 10CM THICK SLAB

- When pouring, even out with a rake and spade.
- Spread out the concrete with a level so that the concrete flows over the top of the level markers.

For 1m<sup>2</sup> of concrete at a 350 kg mix, the composition should be the following :

- 350 kg of cement CPJ 45 R
- gravel (calibre 6.3 to 16)
- sand (calibre 0.08 to 6.3)

Mixed in 170 litres of water.

This mix can be delivered by specialist companies in a "ready-mix" lorry, in two ways:

\*By a "conveyor belt" with a span of 9 to 12m. These normally carry 6 to 10 m<sup>3</sup>.

\*By a concrete pump, from a "ready-mix" lorry to the pouring point. This allows the concrete to be carried further and avoids access problems to the site, but is more expensive.

Slab, thickness 10 cm						
			FP	PC	TP	FI
8	x	4	3,83	3,87	4,98	4,4
9	x	4	4,28	4,32	5,56	4,92
10	x	5	5,78	5,83	7,51	6,65
11	x	5	6,33	6,38	8,23	7,28
12	x	6	8,13	8,19	10,57	9,35

Concrete quantity in m<sup>3</sup>

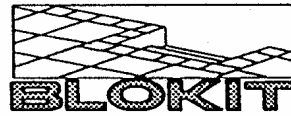

## INSTALLING THE STRUCTURE

### INTRODUCTION

For 1,50m Flat Based Pools, the bottom row of blocks are reduced by 10cm in the factory ( on their lower side ).  
For Sloping Based pools, the blocks are also cut in the factory to suit the shape of the base of the pool.

	Walls -Qty of Concrete in m <sup>3</sup>		
	H = 1,06	H = 1,50	Sloping
8 x 4	3,31	4,69	3,95
9 x 4	3,58	5,06	4,34
10 x 5	4,11	5,81	5
11 x 5	4,37	6,19	5,4
12 x 6	4,9	6,94	6,06

### -PLACING THE BLOCKS

On the finished slab, trace a string line to correspond to the internal dimensions of the pool.

Check that the lines are straight and that the diagonal dimensions are correct.

Place the vertical steel bars and tie them to the starter bars.

On the line, start placing the blocks, starting with a corner:

-Always make sure that the "pills" of the blocks are at the bottom

-Place the stoppers in the corner blocks, in order to stop the concrete from flowing out.

-Use a knife to cut out a passage between the two corner blocks, so that there is a continuous run of concrete at this point.

-Place the second row, overlapping by 0,25m with the first row. Start with a corner.

Place the stoppers and carry out the necessary corner cutouts.

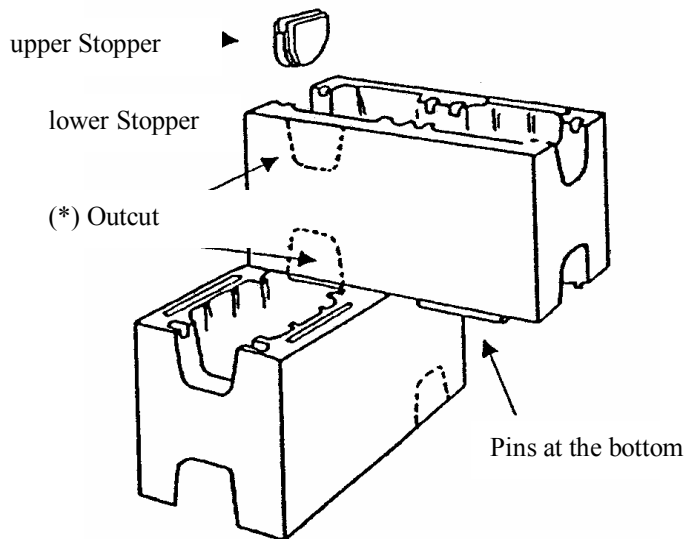

*Dia. 8*

At this stage of the operation, check the length, width and diagonals.

Block the first row of BLOKITS with a 350 kg mix of concrete to the top of the starter bars.

Make sure that the structure has not moved and check the levels and verticality of the structure.

**OVERLAPPING THE BLOKITS AT THE CORNERS.**

**PLACING THE END STOPPERS.**

**OUTCUTTING THE BLOCKS AT THE CORNERS TO ENSURE CONTINUOUS CONCRETE.**

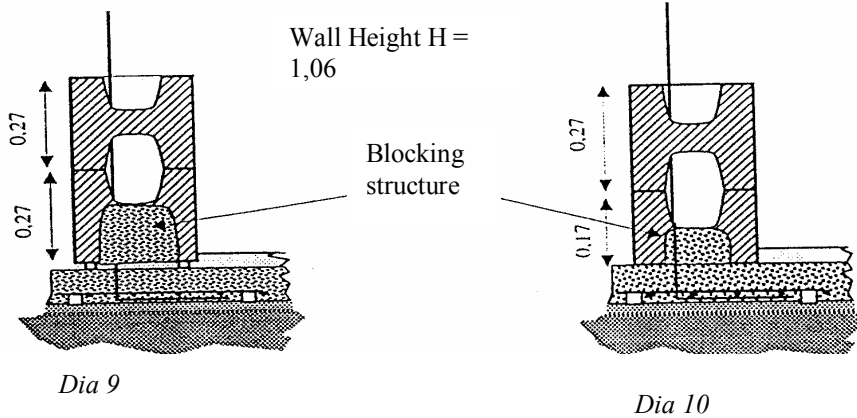
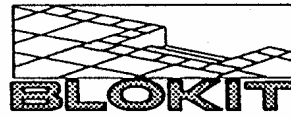

-As soon as the concrete starts to set, place the second row.

Place the steel bars in the first row, tying them to the horizontal steel bars and making sure that the horizontal bars are toward the outer side of the BLOKITS ( see plans BO08, 009,010 ).

Place the second row, making sure to overlap the blocks.

Continue to assemble the structure up to the top row, not forgetting to tie the horizontal bars to the vertical bars.

Before pouring the concrete in to the structure, it is important to check the verticality of the walls once again, especially if there are steps or automatic cover.

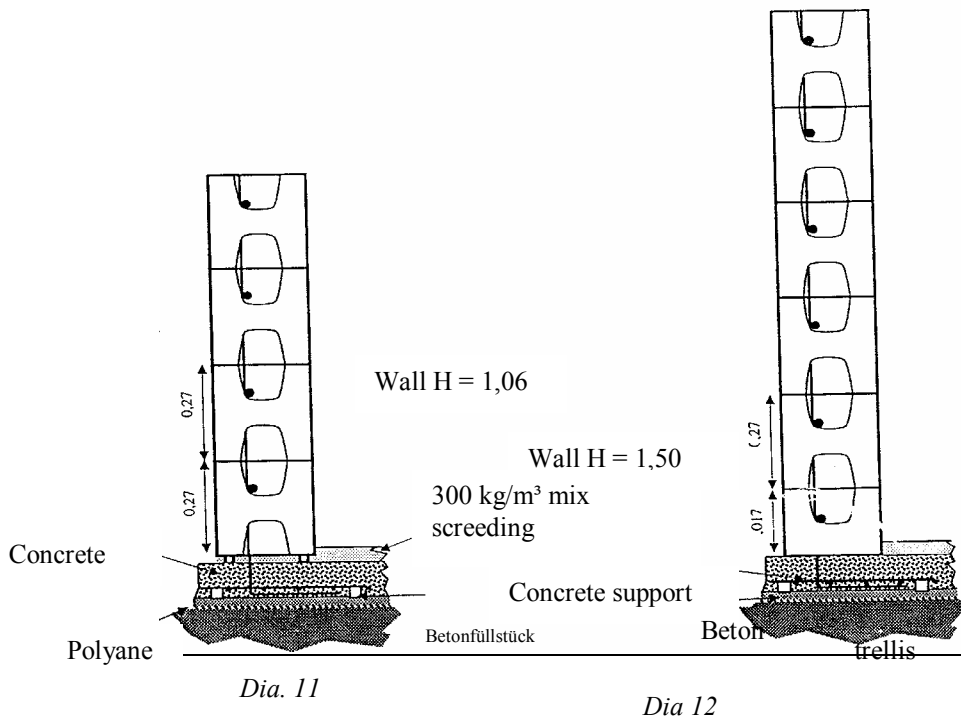

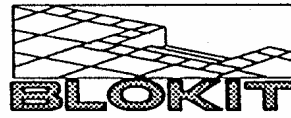

**INSTALLING THE POOL FITTINGS**

The positioning of the pool fittings is determined by various criteria and are set in the polystyrene blocks by outcutting the relevant holes.

Clamps should be used to keep the pool fittings in the correct positions. Use wood so as to not damage the polystyrene.

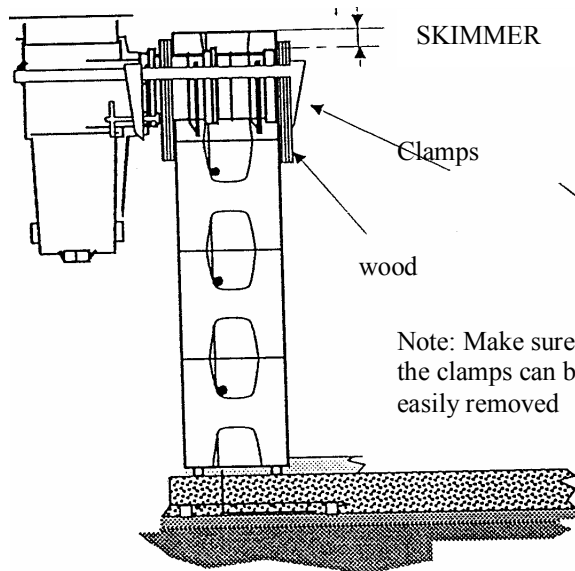

*Dia. 13*

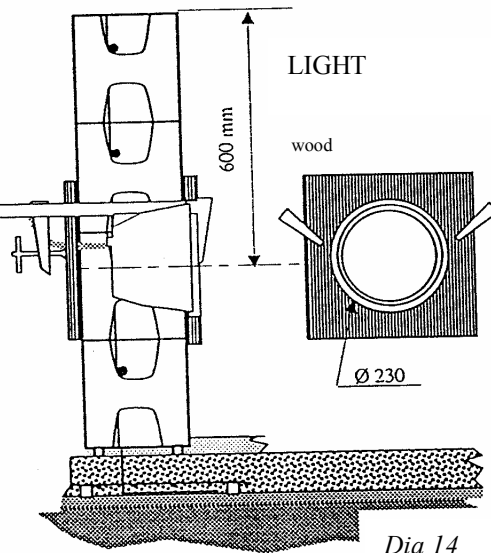

*Dia 14*

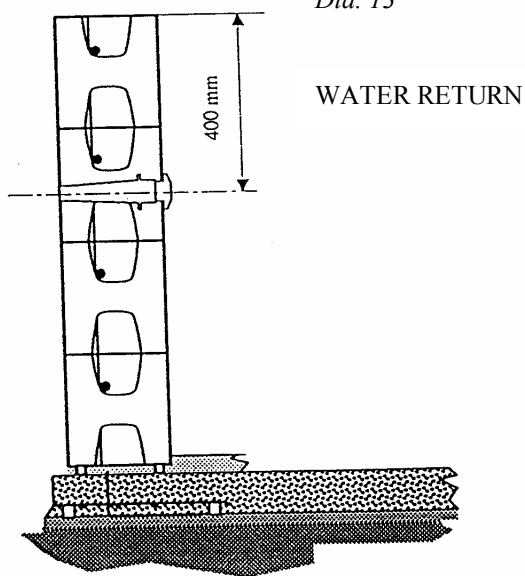

*Dia 15*

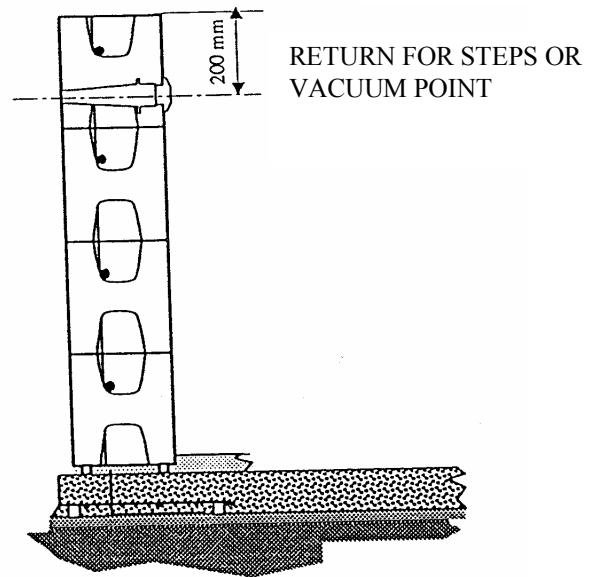

*Dia 16*

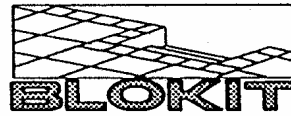

### -POURING THE CONCRETE

For walls upto 1,50m high, pour the concrete in one single pour.

For walls over 1,50m high, particularly for Sloping Base Pools, pour the concrete in two seperate pours.

It is highly recommended to use a vertical pouring conveyor belt, so that the concrete falls on to the funnel then in to the blocks.

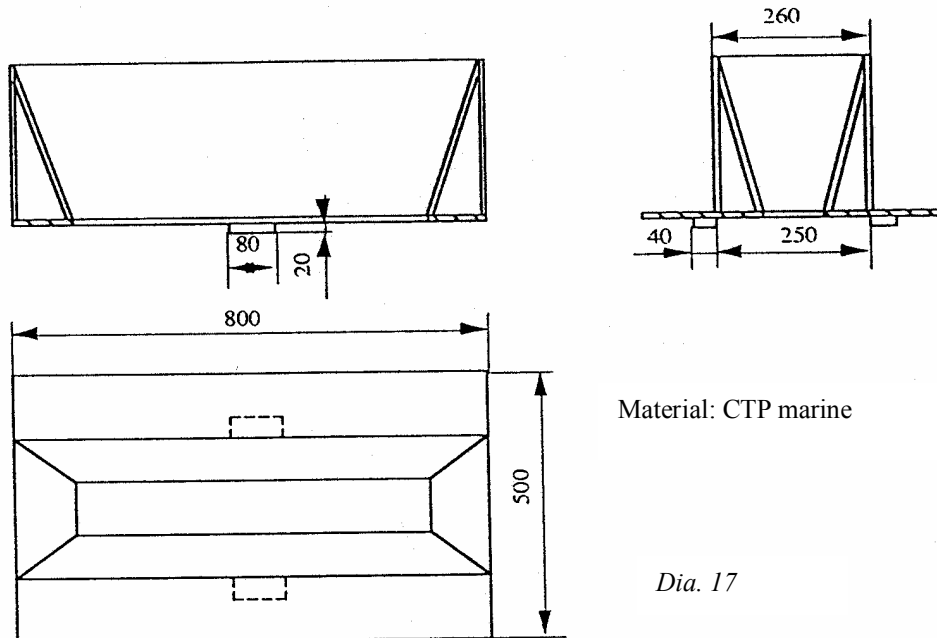

This wooden accessory is placed over the top of the wall and can slide along the wall. It breaks the impact of the concrete when it is poured, directs the concrete and avoids messy waste.

In order to ensure an even spread of concrete, it is useful to pour a second time making sure that the blocks are full to the top.

When pouring, start at a corner and push the wooden funnel around the pool.

### VERY IMPORTANT: .

Just after pouring and before the concrete sets, check for a last time that the walls are straight and upright ( particularly if there are steps or an automatic cover )

If the walls are not perfectly straight, push the wall sufficiently in one direction or the other ( whilst the concrete is still fresh...) by placing supports on the inside or the outside of the pool.

With such a mix, ideal setting time of the concrete is 28 days.

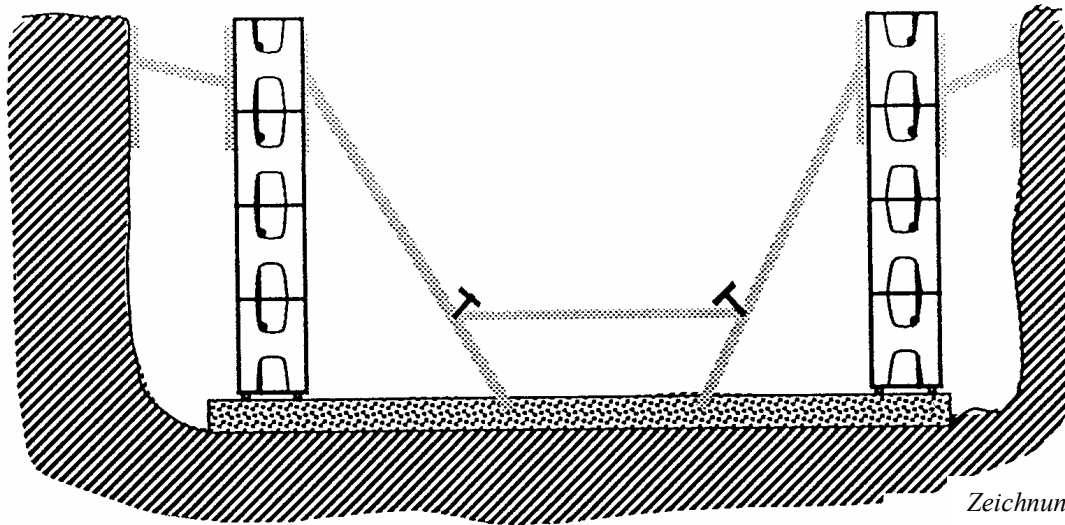
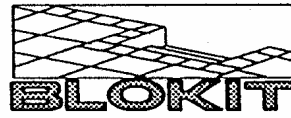

Zeichnung 18

PLACING THE LINER LOCK

-With the concrete still fresh, place the PVC liner lock with the special heel anchored in to the concrete.  
 Every now and then, weigh the liner lock down so that it is held firm by the concrete.  
 If necessary , clean the structure.

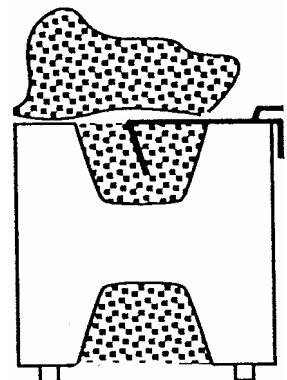

Dia 18

SCREEDING

Once the concrete has set, take the shuttering off of the pool fittings.  
 Clean the pool base.  
 Place a 4cm screed ( with concrete mixed at 300kg / m3 slowly sloping down towards the main drain ( dia 20 ).

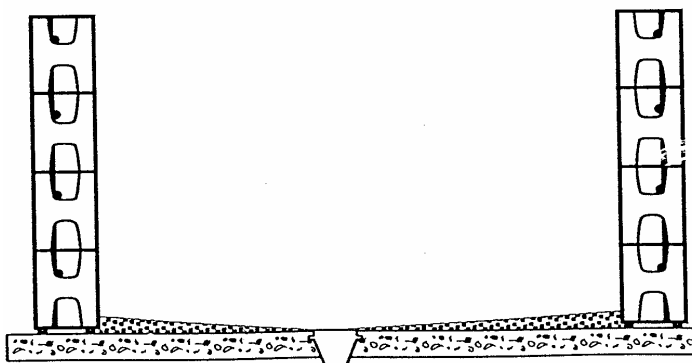

Dia 20

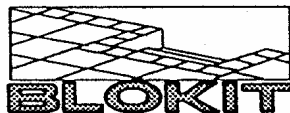

### FINISHING OFF THE STRUCTURE

#### PLACING THE EXTERNAL PROTECTION SHEET (Dia no 21)

In order to avoid any possibility of damage, it is important to install the external protection sheeting on the outside of the BLOKITS.

This sheeting is delivered in rolls and is placed around the outside of the perimeter of the pool.

For a 1,06m high pool, the roll will be 1,26m high

For a 1,50m high pool, the roll will be 1,70m high.

This protection glue is occasionally glued.

#### PLACING THE INTERNAL PROTECTION SHEETS

Just before installing the liner and after cleaning the structure, place the internal protection sheet which is delivered in individual pieces.

1,04 x 1,34 for 1,06m high pools

1,48 x 1,34 for 1,50m high pools

Use the glue supplied by the manufacturer by first placing the glue on to the blocks.

Use this same glue to place the polystyrene corner profiles in the vertical corners of the pool, over the whole height of the wall,

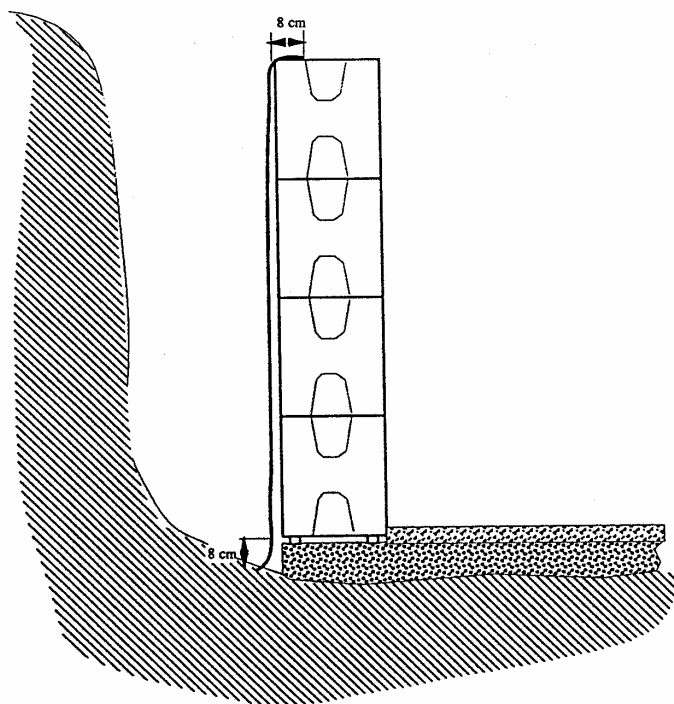

*Dia 21*



**MYPOOLDIRECT**  
Swimming Pool & Enclosure European Distributor

**UK SALES OFFICE: +44 (0) 1268 710425**

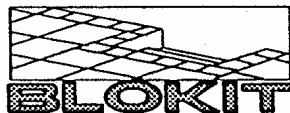

## HOW TO BUILD FREE-FORM BLOKIT POOLS

### CHARACTERISTICS

The BLOKIT Free-Form structure contains 3 products:

-One module 1500m long, 250mm wide and 270mm high open at both ends, and with 6 slots down one side to receive Free Form "Pins" (dia 23).

-The Free Form "Pins", marked in the mould on their outer side with a number ( 0-1-2-3-4-5-11-12) to allow the blocks to be forced onto various radius' (including Roman ends 3m in diameter).

--These blocks can be used with straight BLOKITS

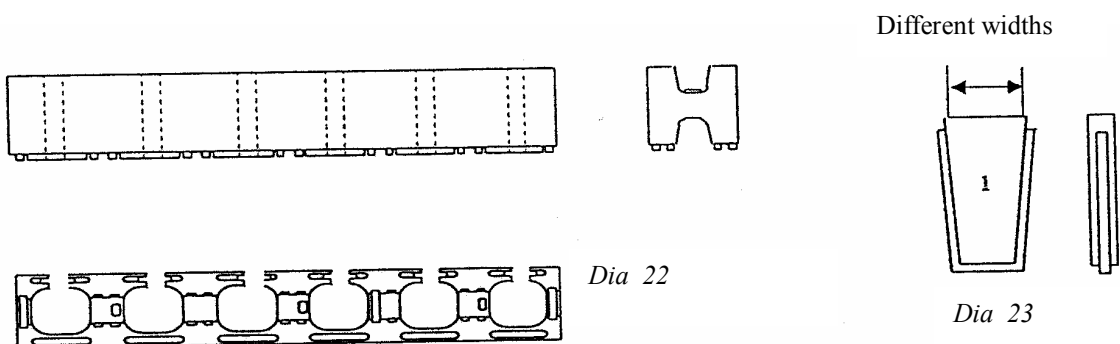

### -NOTE

The excavation and slab are carried out following the same principle as for the rectangular pools -please refer to the preceding pages for the details.



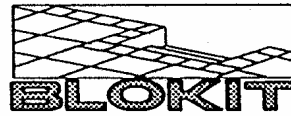

## ASSEMBLING THE STRUCTURE

### GENERALITIES

-Refer to the plans giving the details of the positioning and the bending of the blocks according to the type of pool involved.

-Prepare the first and second row of BLOKITS, firstly making sure that they are correctly bent.

-Insert the Free Form "Pins" into the 6 corresponding slots in th BLOKITS, respecting the numbers on the pins and on the plans This is the only way of being sure to have the Correct shape.

### **To make it easier to insert them, firstly wet them**

-Prepare the horizontal steel bars

Place the first two rows of BLOKITS, following the procedure below:

a) Place the first two rows, starting from point A and following the assembly direction ( see plans B051, 052,053 ). Make sure that the structure fits together properly with the blocks lining up.

### **b) Check all of the dimensions at this stage.**

c) Drill the slab every 0,50m to fix the vertical bars. Position the steel bars towards the outer side of the blocks ( plan 050).

d) Position the first row again.

e) Mortar around the vertical steel bars.

f) Place the first row of horizontal steel bars in the relevant groove of the blocks (towards the outside of the blocks).

g) Tie in with the vertical bars.

h) Place the 2nd row starting from point A + 0,25m.

i) Check all of the dimensions again and block the first row into place.

j) Carry out the next stage of the steel reinforcing.

k) Continue placing the blocks up to the top row.

l) Before pouring the concrete into the walls, check the dimensions and the verticality once again.

m) Pour the concrete.

n) After pouring the concrete, and before it dries, check once again that the walls are vertical.

o) Place the liner lock into the fresh concrete. It is necessary to weigh it down occasionally to make sure that it is properly anchored by the concrete.

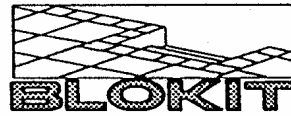

## ROMAN END STEPS

Prepare the Free Form Blokits for the Roman End.

Insert the Free Form "Pins" into the 6 slots along one side of the BLOKIT, making sure to respect their positions as shown on plans B .140 & 142. This is the only way of ensuring that the desired shape is obtained.

- To make it easier to insert them, first wet the slots.
- Place the first two rows of the whole pool, respecting the advice given previously.
- In particular, make sure that the Roman End is the desired true semi-circle.
- By first placing the polystyrene step supports in to place, this operation will be made easier.
- Make the positions for the vertical steels and drill the holes for the starter bars every 0,50m towards the outside of the blocks.
- Reposition the first row and tie in the steel bars.
- Reposition the second row and tie in the horizontal steel bars.
- Bind together the joint between the Free Form and the straight BLOKITS with double sided adhesive tape.
- Block the first row into place by pouring concrete up to the level of the grooves inside.
- Check all of the dimensions once again.
- Continue assembling the structure and the steel reinforcing.

Use double-sided adhesive tape to join the Free Form and straight BLOKITS on the other rows ( dia 24 ).

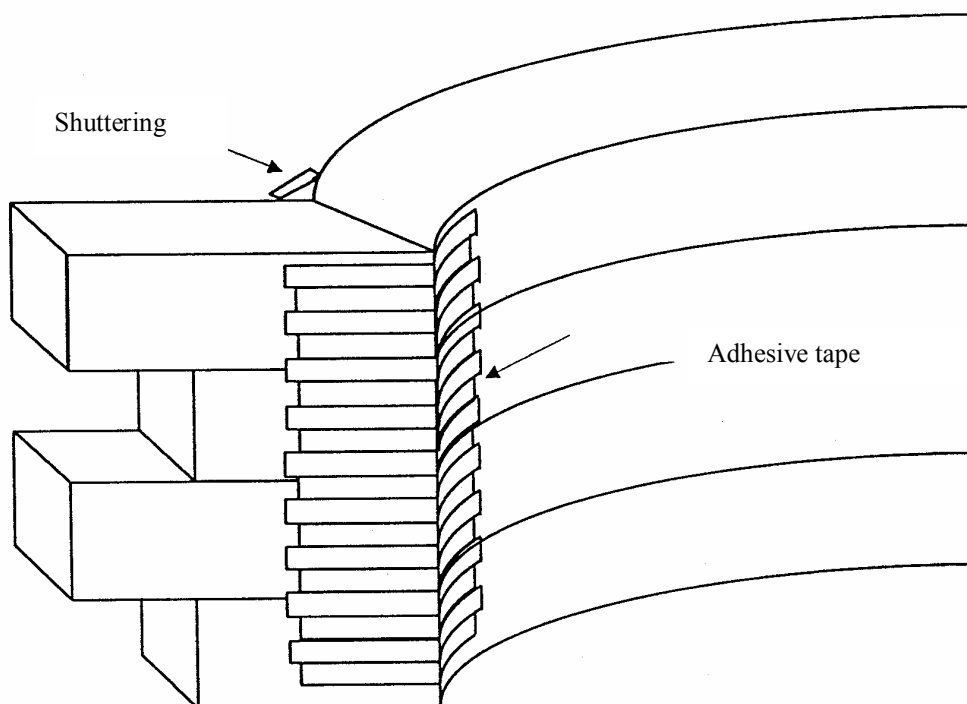

*Dia 24*

Before and after pouring the concrete check once again all of the dimensions at the top and at the bottom of the structure.

On the finished concrete slab, perfectly level and smooth, block the structure and steps into place with concrete.

### NOTE

Where there is a high water table, it is highly unadvisable to install pre-fabricated steps.

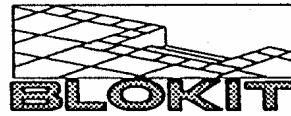

## LIST OF TECHNICAL PLANS

Positioning the steel bars in respect of the shuttering	BOO 1
Installing the Pool Fittings	B 002
Intalling Badujets and Bellowjets	B 003
Pit for Automatic Cover	B 004
Extension for Automatic Cover	B 006
I Manhole for Automatic Cover Motor	B 007
Steel plan for 1,06m high Wall	B 008
Steel plan for 1,50m high Wall	B 009
Steel plan for sloping based pools	BO10
Drainage plan with well	BO11
Drainage plan by gravity	B012
Funnel	B013
Steps- straight 2,50 x1, 75m	B 020
Steps- straight 2,00 x 1,50m	B 021
Comer Steps	B 023
Curved Base	B 030
Hopper Base	B 031
Comfort Flat Base	B 032
Sloping Base	B 033
Hopper Base ( TP DEP)	B 034
Steep Plan for Free Form pools	B 050
Oval Pools J	B 051
Kidney Pools	B 052
"Haricot" Pools	B 053
Oval Pools -Curved Base	B 060
Oval Pools -Hopper Based	B 061
Oval Pools -Flat Based 1,50m	B 063
Kidney Pools -Curved Base	B 070
Kidney Pools -Hopper Base	B 071
Kidney Pools -Flat Base 1,50m	B 072
"Haricot" Pools -Curved Base	B 080
"Haricot" Pools -Hopper Base	B 081
"Haricot" Pools -Flat Base 1,50m	B 082
Structure 7 x 3 Hopper & FB 150	B 100
Structure 8 x 4 Hopper & FB 150	B 101
Structure 9 x 4 Hopper & FB 150	B 102
Structure 10 x 5 Hopper & FB 150	B 103
Structure 11 x 5 Hopper & FB 150	B 104
Structure 12 x 6 Hopper & FB 150	B 105
Structure 8 x4 Sloping Base	B 110
Structure 9 x 4 Sloping Base	B 111
Structure 10 x 5 Sloping Base	B 112
Structure 11 x 5 Sloping Base	B 113
Structure 12 x 6 Sloping Base	B 114
Structure OV I	B 120
Structure OV II	B 121
Structure OV III	B 122
Structure OV IV	B 123
Structure Kidney I	B 130
Structure Kidney II	B 131
Structure Haricot I	B 135
Structure Haricot II	B 136
Roman 3m structure	B 140
Roman 3m steps	B 141
Roman 4m structure	B 142
Roman 3m steps	B 143

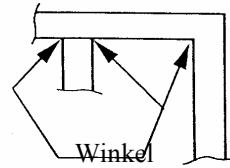
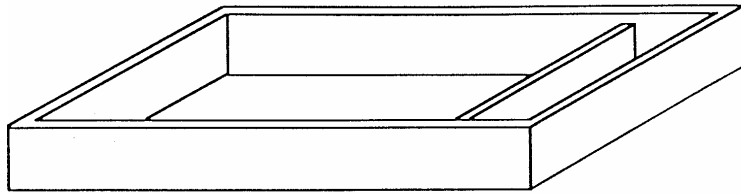
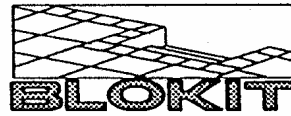

### POSITION SKIMMER UND ÜBERLAUF

- \* An der Beckenbreite auf der Seite der automat. Abdeckung muss ein Überlauf und mindestens ein Skimmer sein.
- \* Bei Montage der anderen Bauteile (Skimmer auf den Längsseiten, Einbau rückspringend im Verhältnis zum fertigen Mauerwerk (Außenseite der Flansch-Abdeckung senkrecht zur Mauer)

### **Für den Schacht:**

- 1 Skimmer
- 1 Bodenablauf
- 1 Niveaugler
- 1 Überlauf
- 1 Schutz für die oberen Ecken der Trennmauer (Eckstück aus PVC)

### **FÜHRUNGSSCHIENE 100 x 100**

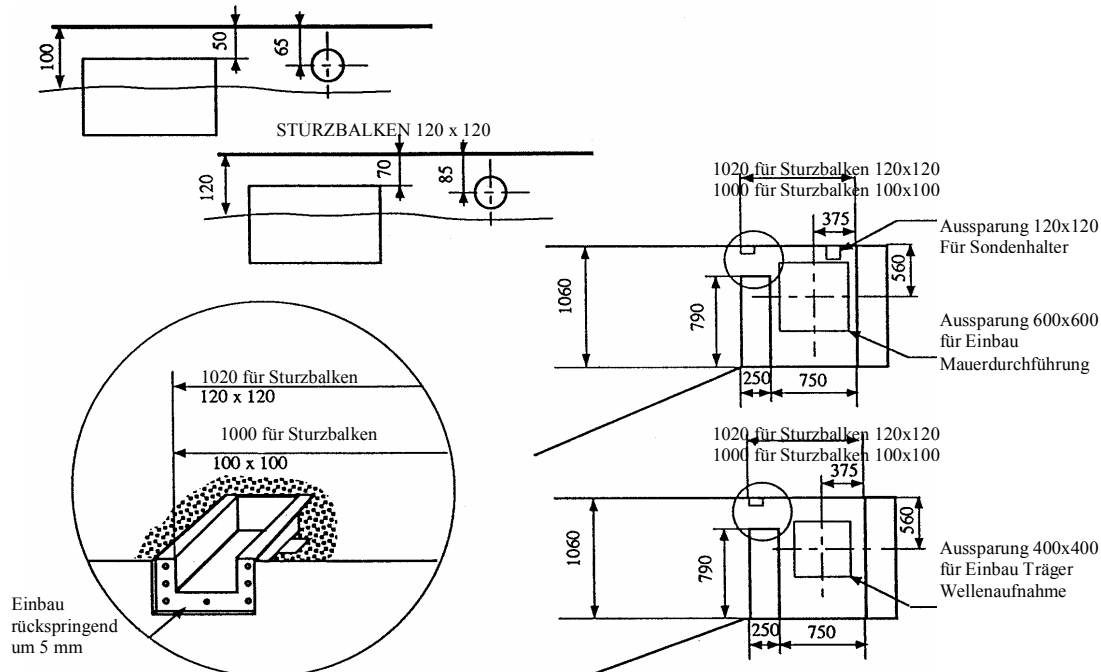

### **WICHTIG:**

Die Trennwand darf nicht zusammen mit dem Becken hinterfüllt werden.

Die Stopper (H+B) müssen an den Außenblöcken von BLOKIT befestigt werden, die die Beckenmauern berühren.

Die Trennwand und die Beckenwände werden in jeder Reihe mittels eines Eisenstabes Ø 6, der durch die Innenwand geht, mit der bereits existierenden Armierung verbunden wird.

## **TECHNISCHE ZEICHNUNG**

### **BLOKIT MIT SCHACHT FÜR AUTOMATISCHE ABDECKUNGEN**

Weitere Informationen finden Sie in der technischen Anleitung für automatische Abdeckungen.

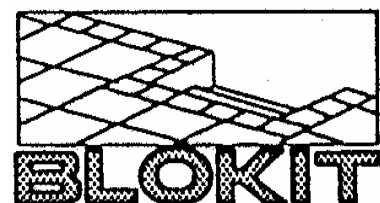

**ZEICHNUNG B 005**

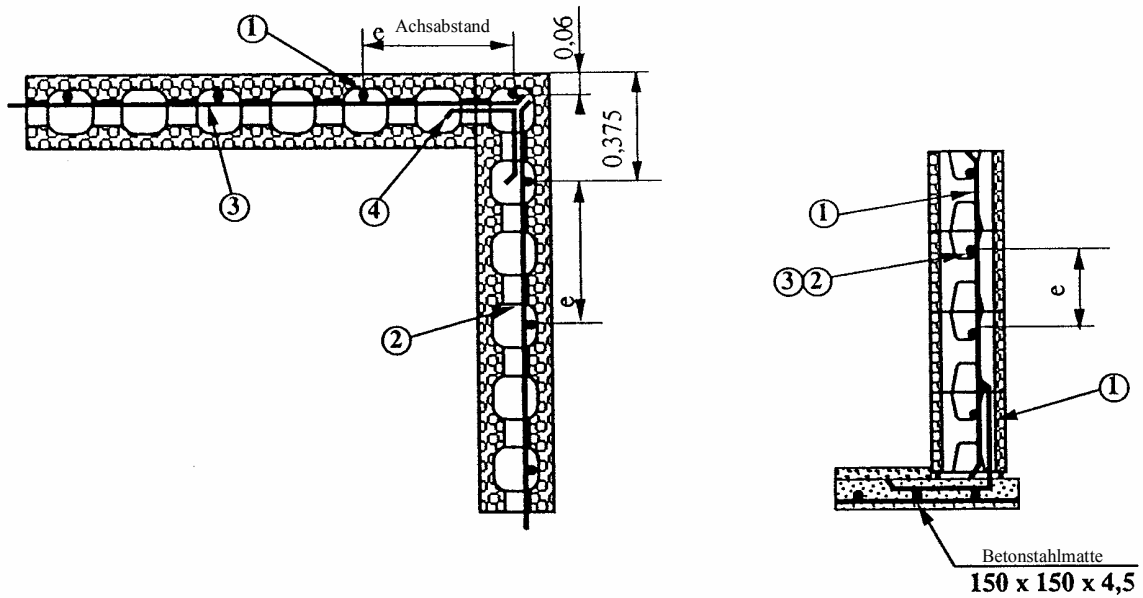
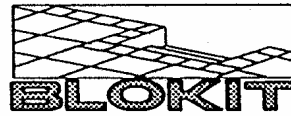

N° \ L x l	8 x 4	9 x 4	10 x 5	11 x 5	12 x 6
①	48T8x0,55 +48T8x1,03 e=50cm	52T8x0,55 +52T8x1,03 e=50cm	60T8x0,55 +60T8x1,03 e=50cm	64T8x0,55 +64T8x1,03 e=50cm	72T8x0,55 +72T8x1,03 e=50cm
②	8T6x4,30 e=27cm	8T6x4,30 e=27cm	8T6x5,30 e=27cm	8T6x5,30 e=27cm	8T6x6,30 e=27cm
③	8T6x8,30 e=27cm	8T6x9,30 e=27cm	8T6x10,30 e=27cm	8T6x11,30 e=27cm	2x8T6x6,15 e=27cm
④	16T6x0,4 e=27cm	16T6x0,4 e=27cm	16T6x0,4 e=27cm	16T6x0,4 e=27cm	16T6x0,4 e=27cm
Gesamtgewicht	47 kg	55 kg	62 kg	66 kg	74 kg

## TECHNISCHE ZEICHNUNG

### ARMIERUNG FÜR MAUER H = 1,06

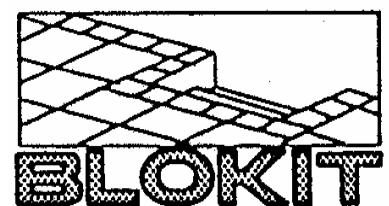

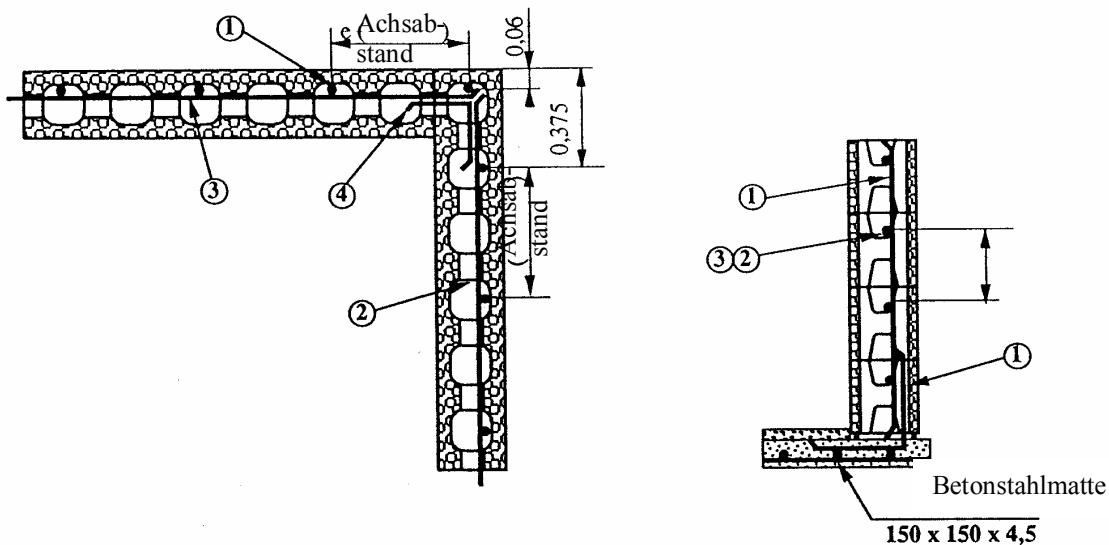
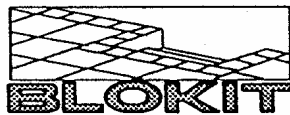

	8 x 4	9 x 4	10 x 5	11 x 5	12 x 6
①	48T8x0,55 +48T8x1,03 e=50cm	52T8x0,55 +52T8x1,03 e=50cm	60T8x0,55 +60T8x1,03 e=50cm	64T8x0,55 +64T8x1,03 e=50cm	72T8x0,55 +72T8x1,03 e=50cm
②	8T6x4,30 e=27cm	8T6x4,30 e=27cm	8T6x5,30 e=27cm	8T6x5,30 e=27cm	8T6x6,30 e=27cm
③	8T6x8,30 e=27cm	8T6x9,30 e=27cm	8T6x10,30 e=27cm	8T6x11,30 e=27cm	2x8T6x6,15 e=27cm
④	16T6x0,4 e=27cm	16T6x0,4 e=27cm	16T6x0,4 e=27cm	16T6x0,4 e=27cm	16T6x0,4 e=27cm
Gesamtgewicht	47 kg	55 kg	62 kg	66 kg	74 kg

# TECHNISCHE ZEICHNUNG

ARMIERUNG  
FÜR WÄNDE H = 1,50

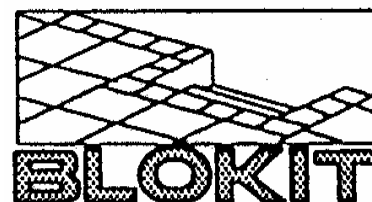

ZEICHNUNG B 009

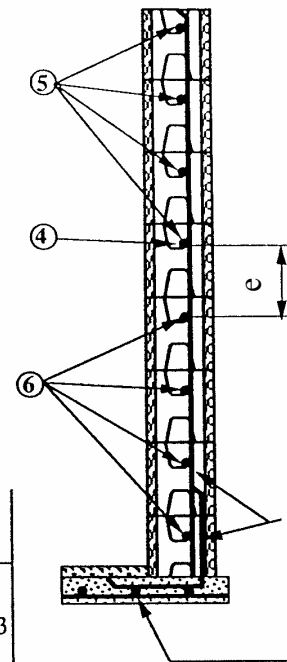
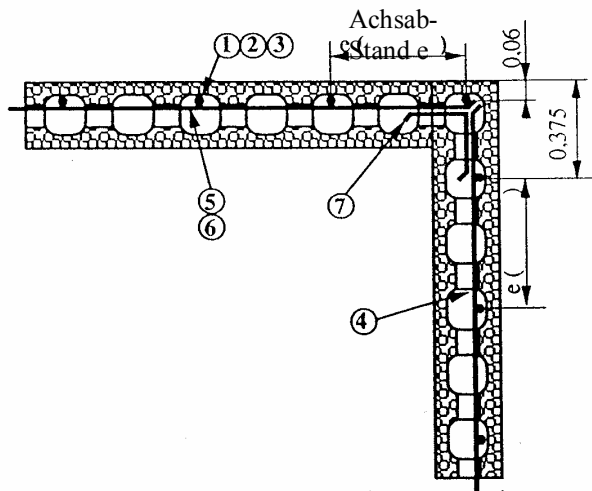
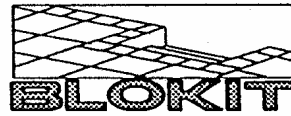

N° \ L x l	8 x 4	9 x 4	10 x 5	11 x 5	12 x 6
①	19T8x0,55 +19T8x1,03 e=50cm	19T8x0,55 +19T8x1,03 e=50cm	21T8x0,55 +21T8x1,03 e=50cm	21T8x0,55 +21T8x1,03 e=50cm	23T8x0,55 +23T8x1,03 e=50cm
②	18T10x0,55 +18T10x var. e=50cm	22T10x0,55 +22T10x var. e=50cm	26T10x0,55 +26T10x var. e=50cm	30T10x0,55 +30T10x var. e=50cm	36T10x0,55 +36T10x var. e=50cm
③	13T14x0,55 +13T14x2,03 e=50cm	13T14x0,55 +13T14x2,03 e=50cm	13T14x0,55 +13T14x2,03 e=50cm	13T14x0,55 +13T14x2,03 e=50cm	15T14x0,55 +15T14x2,03 e=50cm
④	12T6x4,30 e=27cm	12T6x4,30 e=27cm	12T6x5,30 e=27cm	12T6x5,30 e=27cm	12T6x6,30 e=27cm
⑤	8T6x8,30 e=27cm	8T6x9,30 e=27cm	8T6x10,30 e=27cm	8T6x11,30 e=27cm	2x8T6x6,15 e=27cm
⑥	8T6x var. e=27cm	8T6x var. e=27cm	8T6x var. e=27cm	8T6x var. e=27cm	8T6x var. e=27cm
⑦	24T6x0,40 e=27cm	24T6x0,40 e=27cm	24T6x0,40 e=27cm	24T6x0,40 e=27cm	24T6x0,40 e=27cm
Gesamtgewicht	112 kg	120 kg	133 kg	142 kg	164 kg

var. = Veränderliche

## TECHNISCHE ZEICHNUNG

### ARMIERUNG FÜR UNTERGRUND MIT SCHRÄGE

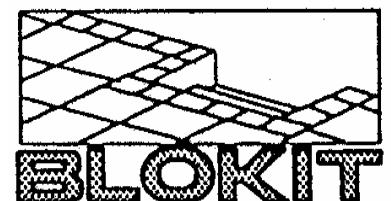

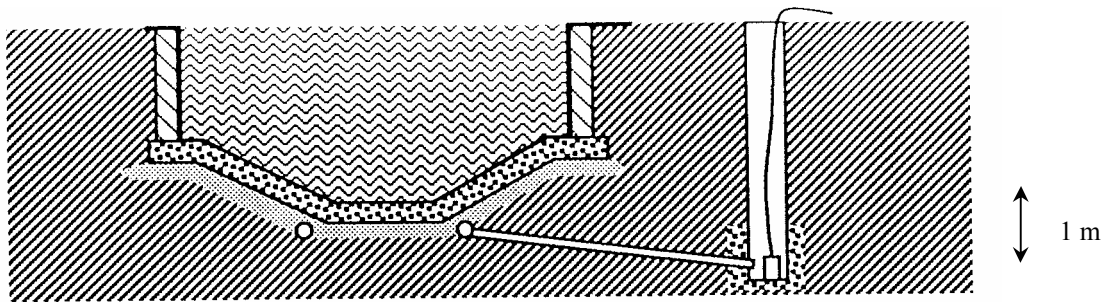
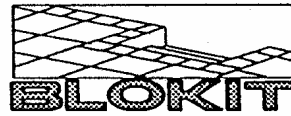

- \* Der Entwässerungsschacht muss so nahe wie möglich am Schwimmbecken sein.
- \* Der Schacht muss tiefer als die tiefste Teil des Schwimmbeckens.
- \* Der Durchmesser der Düse ( $\varnothing$  400 mm) darf in keinem Fall den Schwimmer der Unterwasserpumpe blockieren.

### ENTWÄSSERUNGSSCHACHT

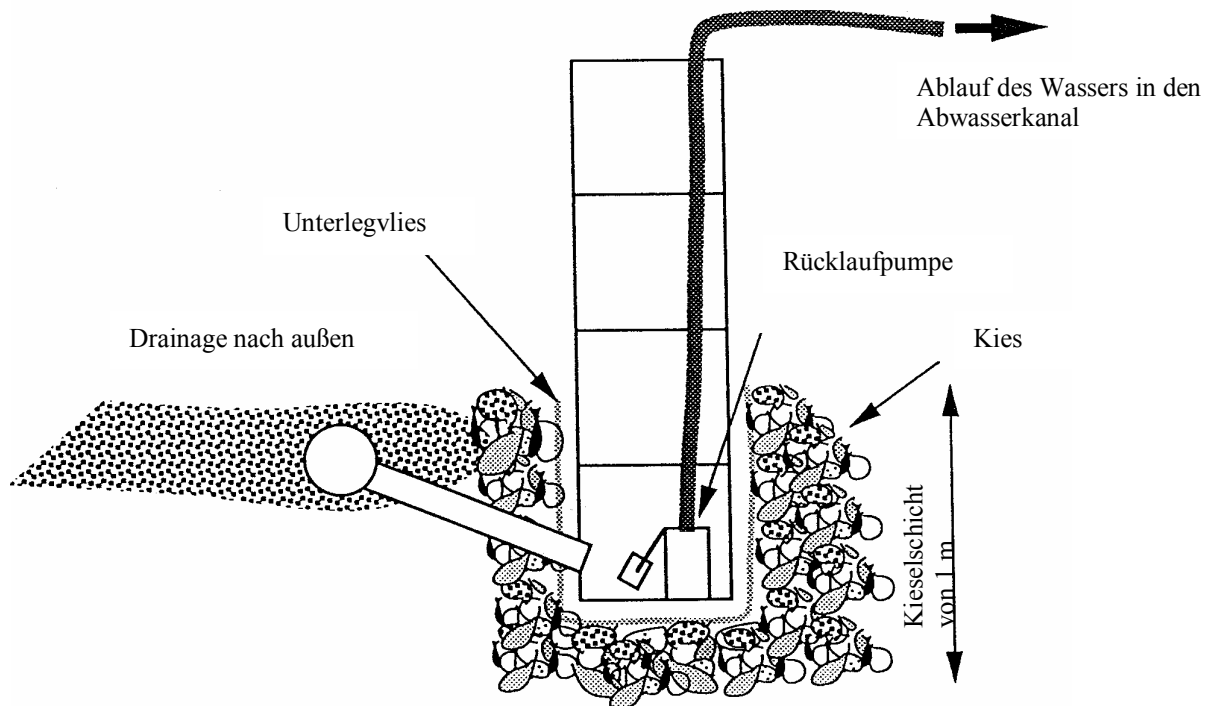

## TECHNISCHE ZEICHNUNG

### DRAINAGE MIT ENTWÄSSERUNGSSCHACHT ODER PUMPENSTUMPF

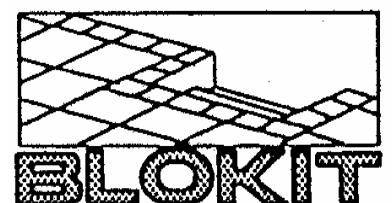



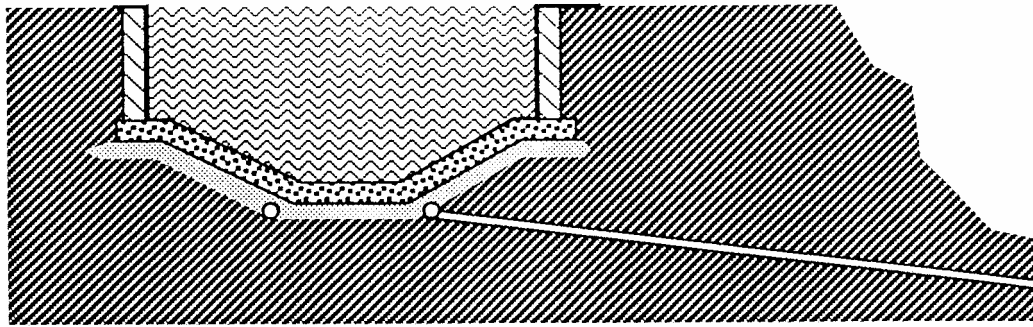
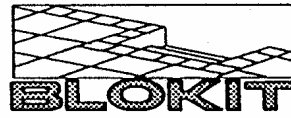

Der Ausgang muss tiefer liegen als die Drainage von außen.

Drainage von außen

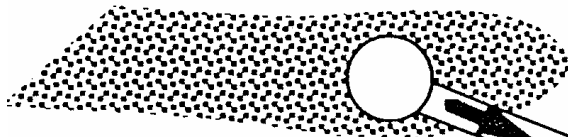

Direkter Wasserablauf  
(Kanalisation, natürlich)

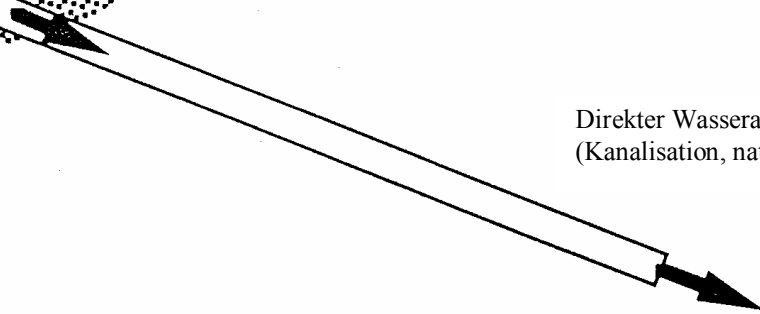

**MYPOOLDIRECT**  
*Swimming Pool & Enclosure European Distributor*

**UK SALES OFFICE: +44 (0) 1268 710425**

**TECHNISCHE ZEICHNUNG**

**DRAINAGE MIT  
ENTWÄSSERUNG NACH GEFÄLLE**

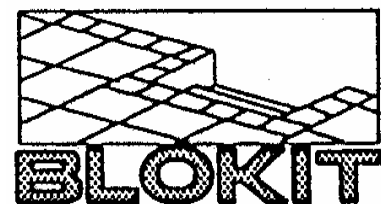

**ZEICHNUNG B 012**

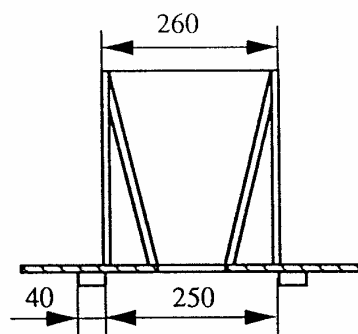
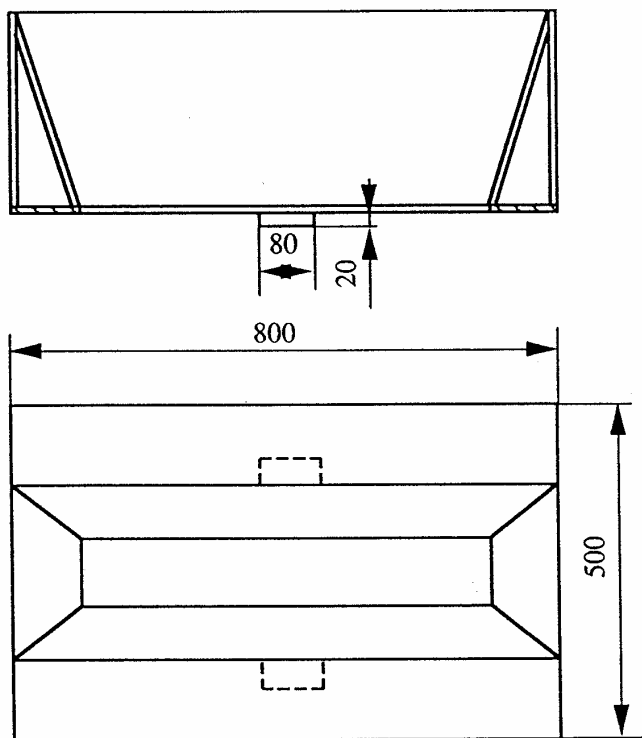
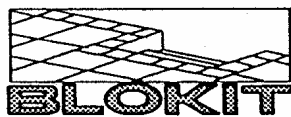

Wasserdichte  
Pressspanplatten

---

# TECHNISCHE ZEICHNUNG

## TRICHTER

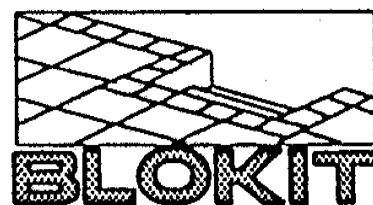

ZEICHNUNG B 013

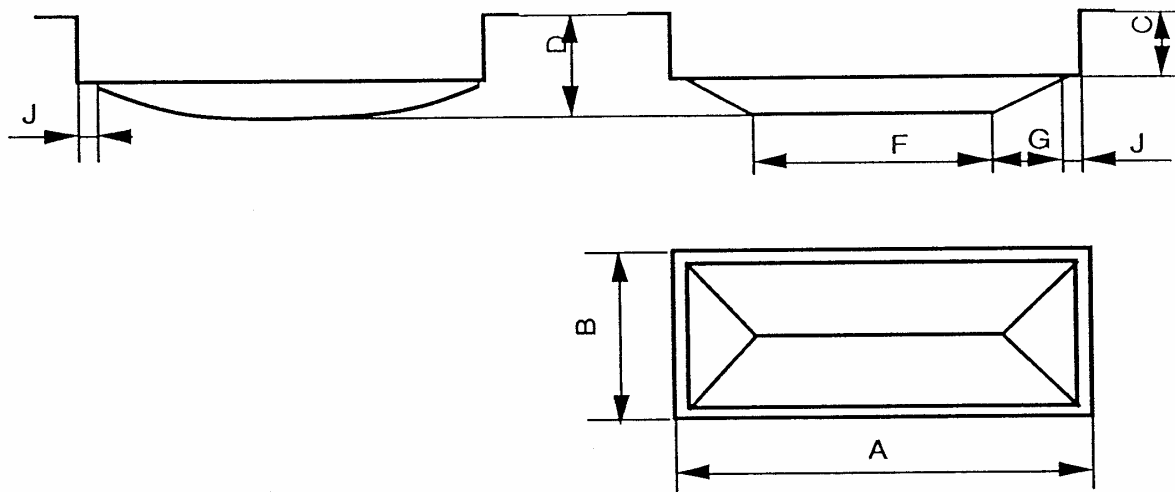
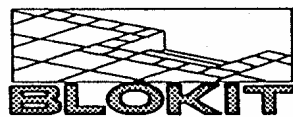

	A	B	C	D	F	G	J
7 x 3	7	3	1,06	1,6	1	2,8	0,2
8 x 4	8	4	1,06	1,6	2	2,8	0,2
9 x 4	9	4	1,06	1,6	3	2,8	0,2
10 x 5	10	5	1,06	1,6	4	2,8	0,2
11 x 5	11	5	1,06	1,6	5	2,8	0,2
12 x 6	12	6	1,06	1,6	6	2,8	0,2

## TECHNISCHE ZEICHNUNG

### DACHFÖRMIGER UNTERGRUND

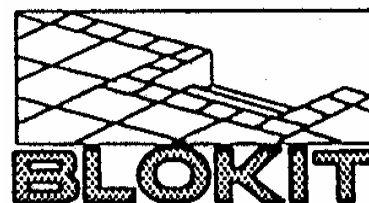

ZEICHNUNG B 030

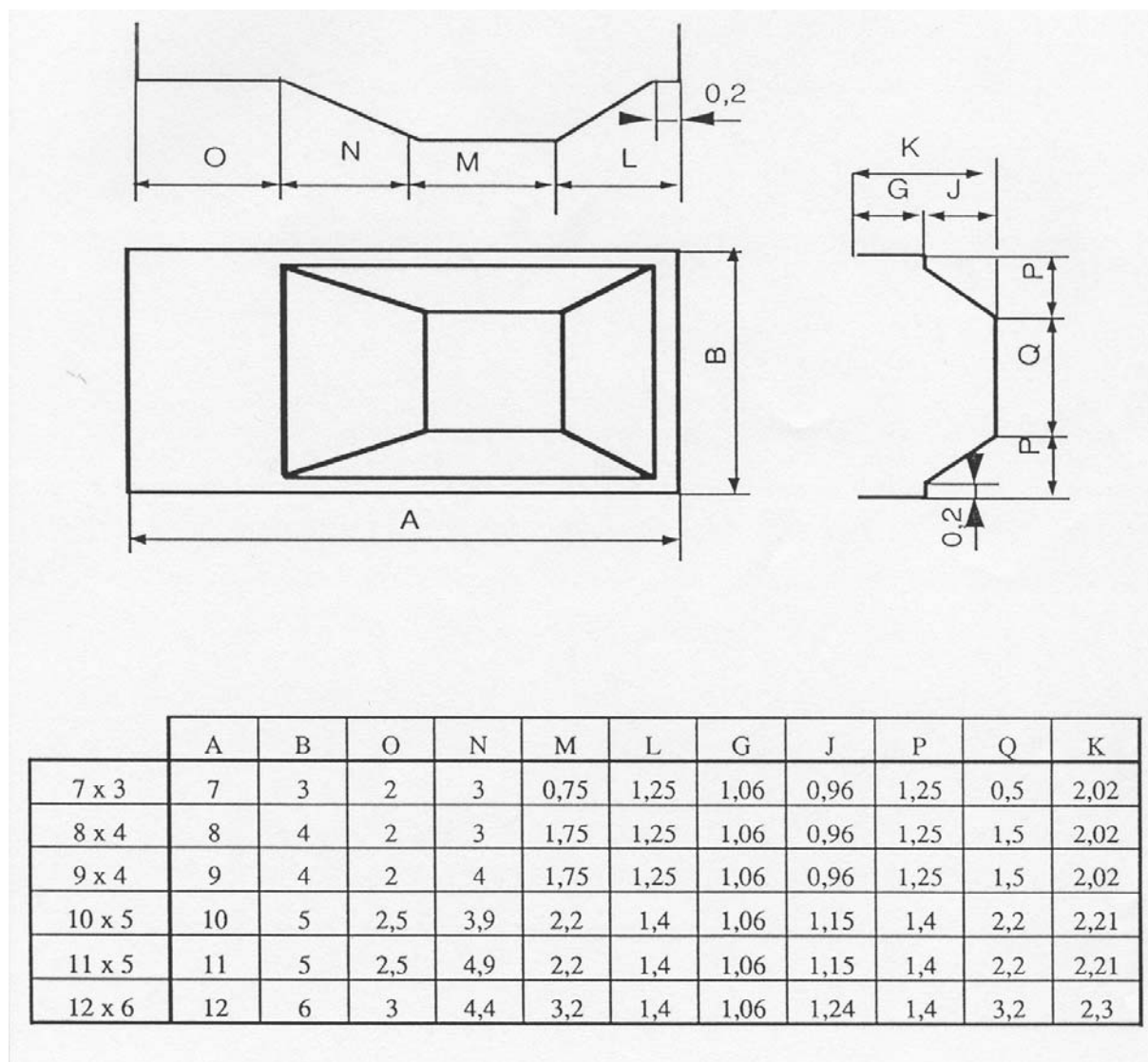
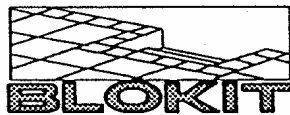

## TECHNISCHE ZEICHNUNG

### PYRAMIDENSTUMPF

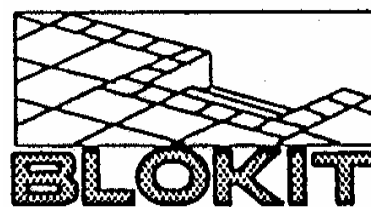

ZEICHNUNG B 031

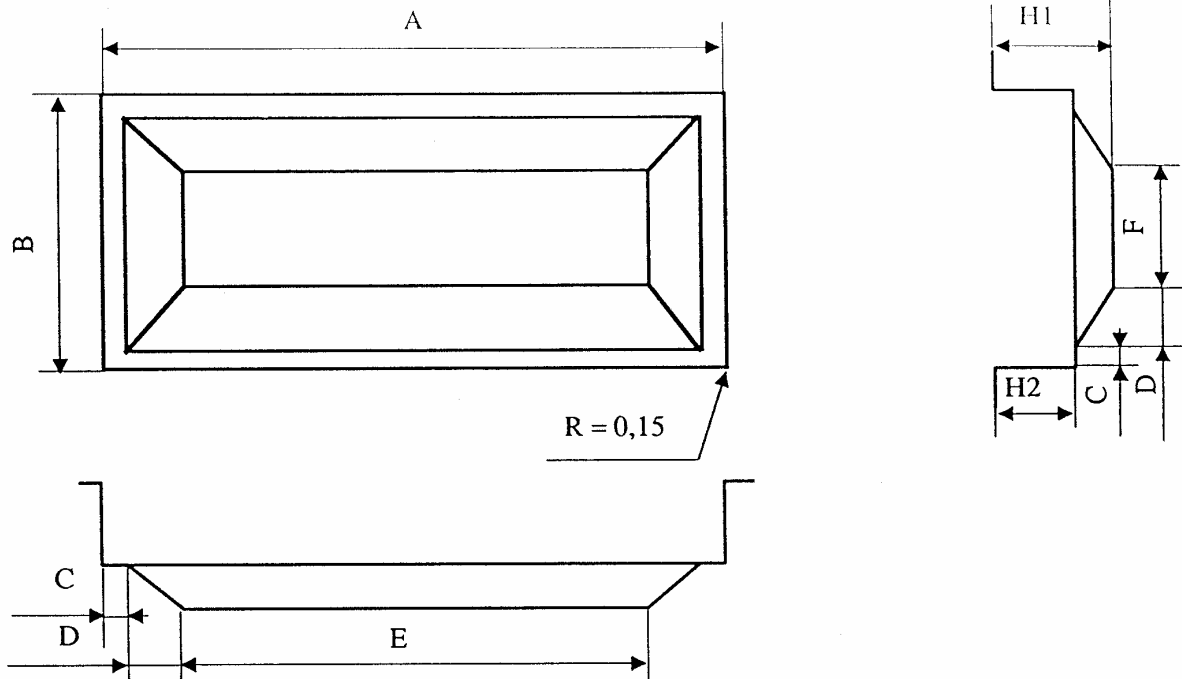
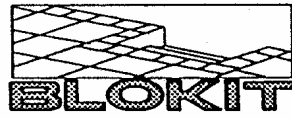

A x B	C	D	E	F	H1	H2
7 x 3	0,20	1,00	4,60	0,60	1,60	1,06
8 x 4	0,20	1,00	5,60	1,60	1,60	1,06
9 x 4	0,20	1,00	6,60	1,60	1,60	1,06
10 x 5	0,20	1,00	7,60	2,60	1,60	1,06
11 x 5	0,20	1,00	8,60	2,60	1,60	1,06
12 x 6	0,20	1,00	9,60	3,60	1,60	1,06

## TECHNISCHE ZEICHNUNG

FLACHER UNTERGRUND  
KOMFORT

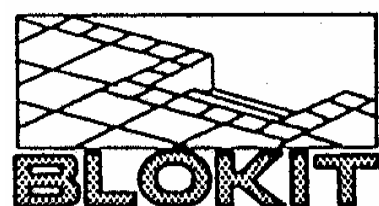

ZEICHNUNG B 032

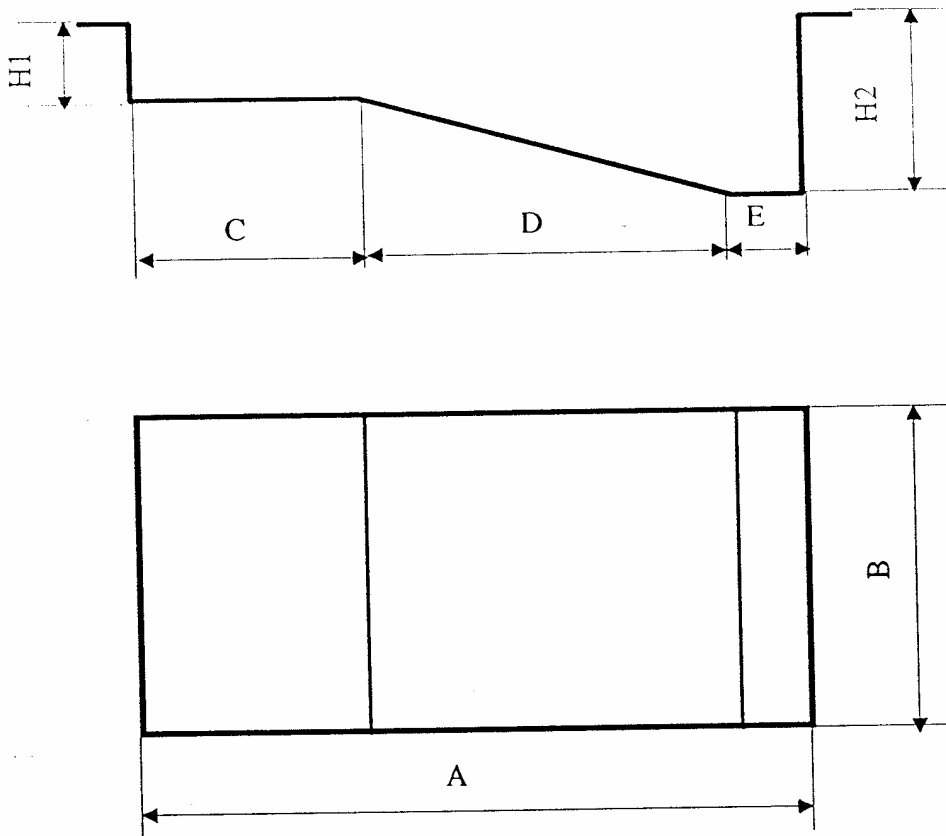
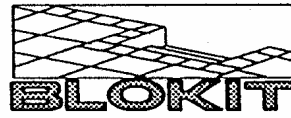

A x B	C	D	E	H1	H2
7 x 3	1,50	4,90	0,60	1,06	2,10
8 x 4	2,50	4,90	0,60	1,06	2,10
9 x 4	2,50	5,90	0,60	1,06	2,10
10 x 5	2,50	6,90	0,60	1,06	2,10
11 x 5	2,50	7,90	0,60	1,06	2,10
12 x 6	2,50	8,90	0,60	1,06	2,10

## TECHNISCHE ZEICHNUNG

UNTERGRUND  
MIT SCHRÄGE

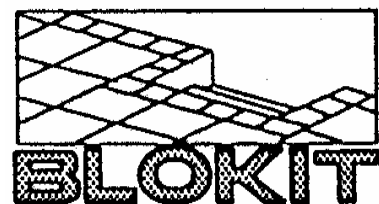

ZEICHNUNG B 033

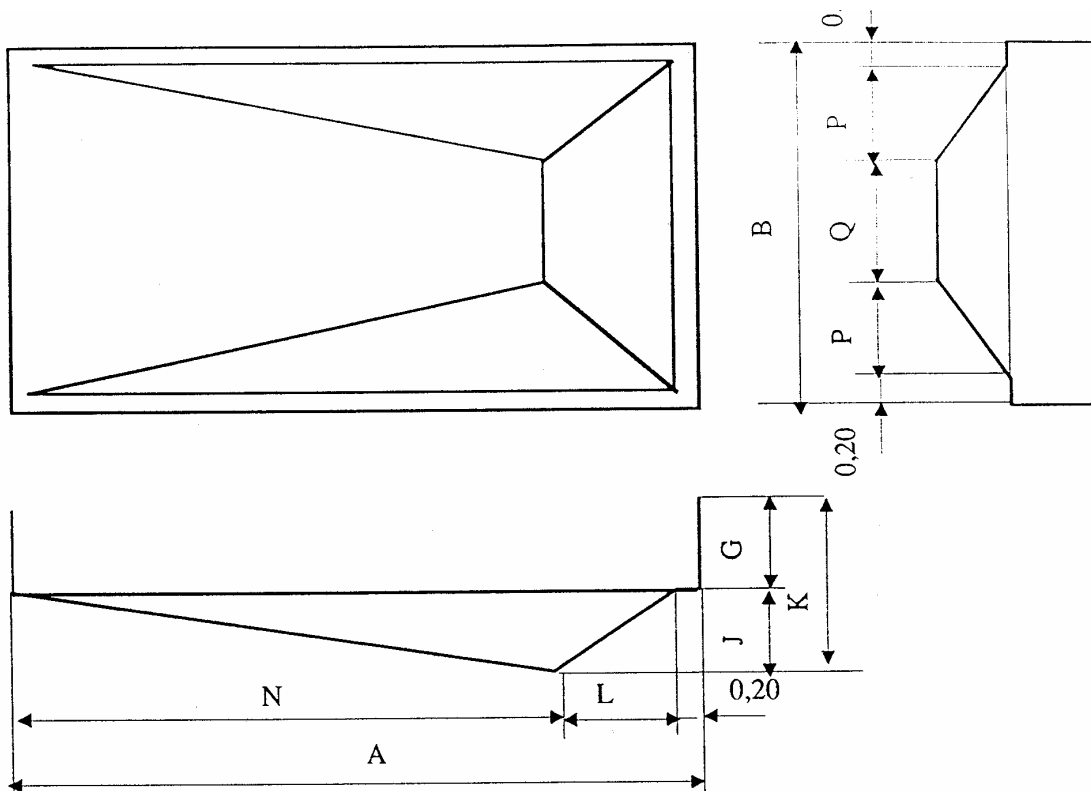
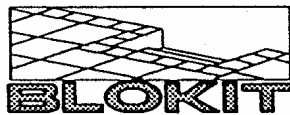

	A	B	N	L	G	J	P	Q	K
7 x 3	7	3	6	0,8	1,06	0,96	0,8	1	2,02
8 x 4	8	4	7	0,8	1,06	0,96	0,8	2	2,02
9 x 4	9	4	7,7	1,1	1,06	0,96	1,1	1,4	2,02
10 x 5	10	5	8,4	1,4	1,06	1,15	1,4	1,8	2,21
11 x 5	11	5	9,4	1,4	1,06	1,15	1,4	1,8	2,21
12 x 6	12	6	10,3	1,5	1,06	1,24	1,5	2,6	2,3

# TECHNISCHE ZEICHNUNG

## PYRAMIDENSTUMPF

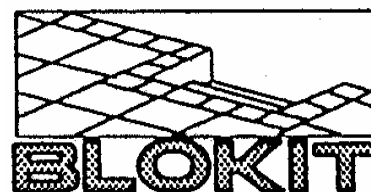

ZEICHNUNG B 034

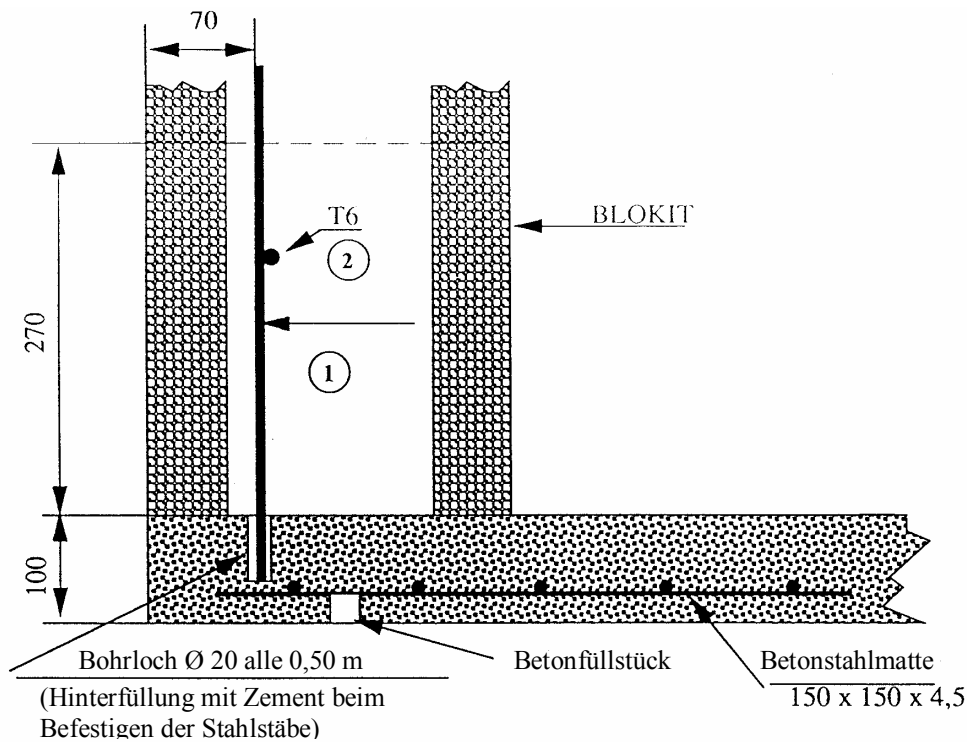
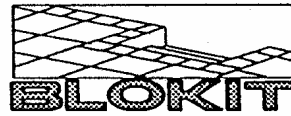

h=1,06	OV I	OV II	OV III	OV IV	KIDNEY I	KIDNEY II	HARICOTI	HARICOTI
①	38T8x1,18 e=50cm	44T8x1,18 e=50cm	50T8x1,18 e=50cm	60T8x1,18 e=50cm	57T8x1,18 e=50cm	64T8x1,18 e=50cm	49T8x1,18 e=50cm	63T8x1,18 e=50cm
②	16T6x6,00 e=27cm	17T6x6,00 e=27cm	20T6x6,00 e=27cm	24T6x6,00 e=27cm	21T6x6,00 e=27cm	24T6x6,00 e=27cm	20T6x6,00 e=27cm	24T6x6,00 e=27cm
Gesamt-Gewicht	39 kg	43 kg	50 kg	60 kg	55 kg	62 kg	50 kg	61 kg

h=1,50	OV I	OV II	OV III	OV IV	KIDNEY I	KIDNEY II	HARICOTI	HARICOTI
①	38T10x1,62 e=50cm	44T10x1,62 e=50cm	50T10x1,62 e=50cm	60T10x1,62 e=50cm	57T10x1,62 e=50cm	64T10x1,62 e=50cm	49T10x1,62 e=50cm	63T10x1,62 e=50cm
②	24T6x6,00 e=27cm	25T6x6,00 e=27cm	30T6x6,00 e=27cm	36T6x6,00 e=27cm	31T6x6,00 e=27cm	36T6x6,00 e=27cm	30T6x6,00 e=27cm	36T6x6,00 e=27cm
Gesamt-gewicht	70 kg	77 kg	90 kg	108 kg	98 kg	112 kg	89 kg	111 kg

## TECHNISCHE ZEICHNUNG

ARMIERUNG  
 FÜR FREIE FORMEN  
 H=1,06 und H=1,50

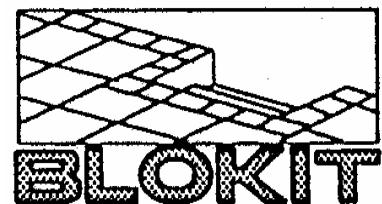

ZEICHNUNG B 050



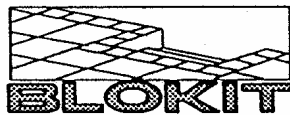

Markieren Sie einen Halbkreis B

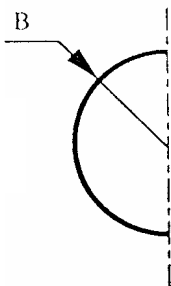

Markieren Sie die Linie H

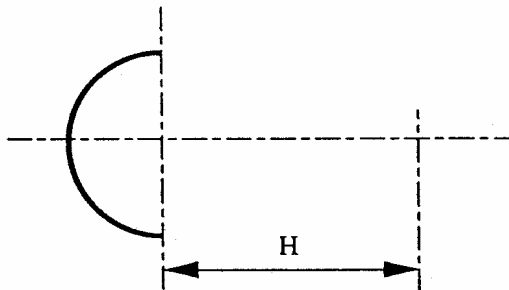

Markieren Sie den Halbkreis B

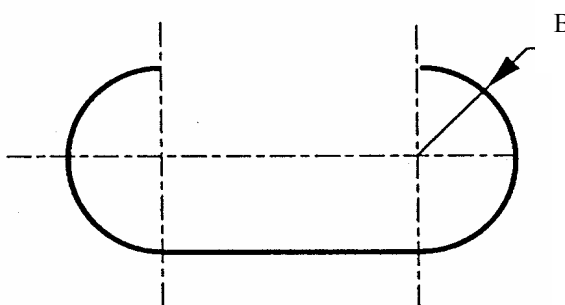

**MONTAGERICHTUNG „BLOKIT“:**

- \* Ausgangspunkt A
- \* Von A nach B
- \* Von A nach C
- \* Von C nach D

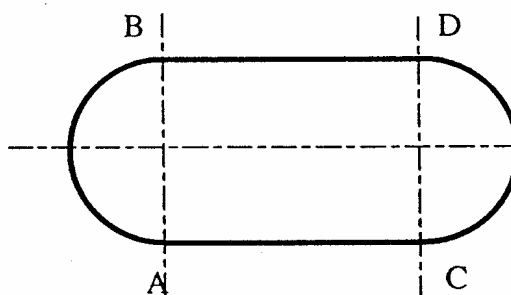



---

## TECHNISCHE ZEICHNUNG

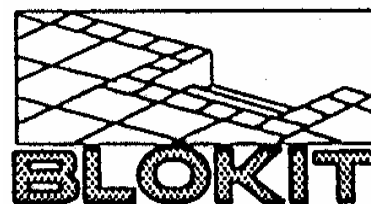
### MONTAGEANLEITUNG FÜR OVALE BECKENFORMEN I, II, III und IV

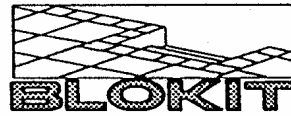

ZEICHNUNG B 051



Markieren Sie einen Halbkreis  $\varnothing B1$ .  
Markieren Sie eine Linie H und die Abmessung L im Winkel von  $90^\circ$ .

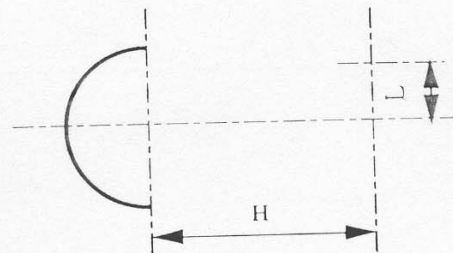

Markieren Sie den Kreis B2.

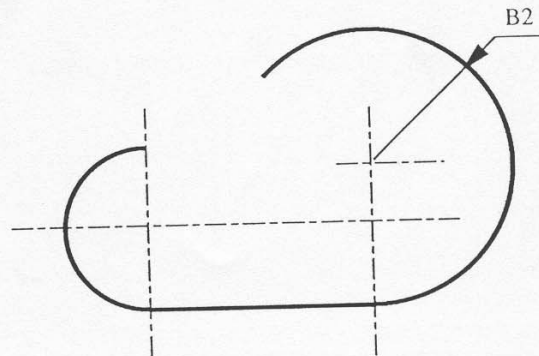

Markieren Sie den Gegenradius ( $R=8,50$ ).

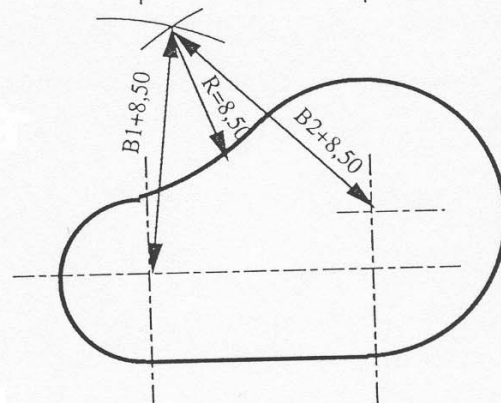

#### MONTAGERICHTUNG VON BLOKIT

- \* Ausgangspunkt A
- \* Von A nach B
- \* Von A nach C
- \* Von C nach D

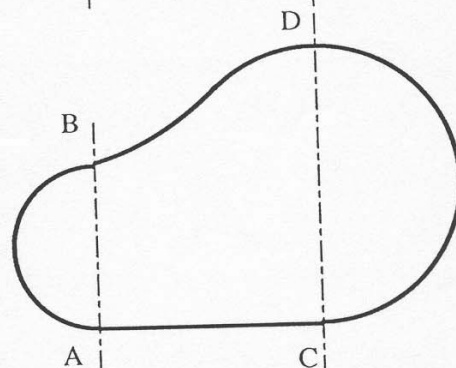

## TECHNISCHE ZEICHNUNG

### MONTAGEANLEITUNG KIDNEY I und II

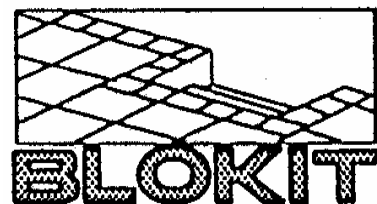

ZEICHNUNG B 052

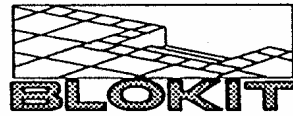

Zeichnen Sie ein perfektes Trapez.

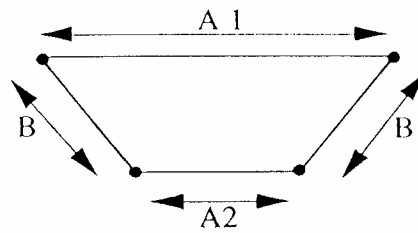

Ermitteln Sie den Mittelpunkt der Radien R1, R2 und R3.

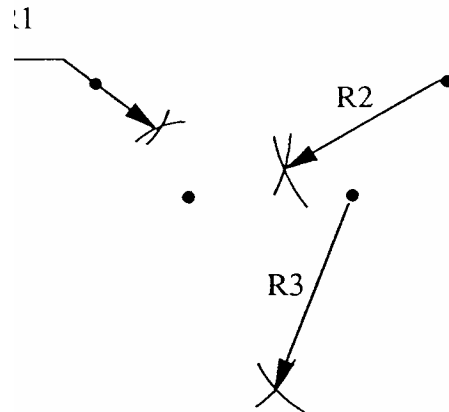

Zeichnen Sie die entsprechenden Bögen.

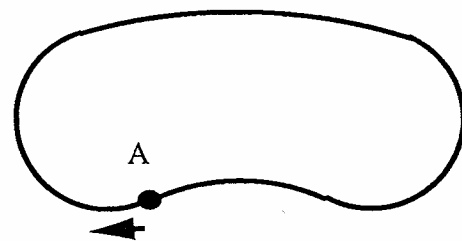

MONTAGERICHTUNG BLOKIT

## TECHNISCHE ZEICHNUNG

MONTAGEANLEITUNG  
FÜR HARICOT I und II

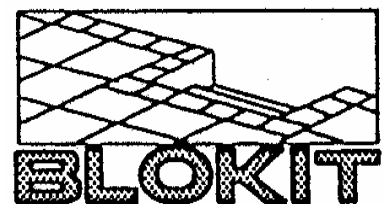

ZEICHNUNG B 053

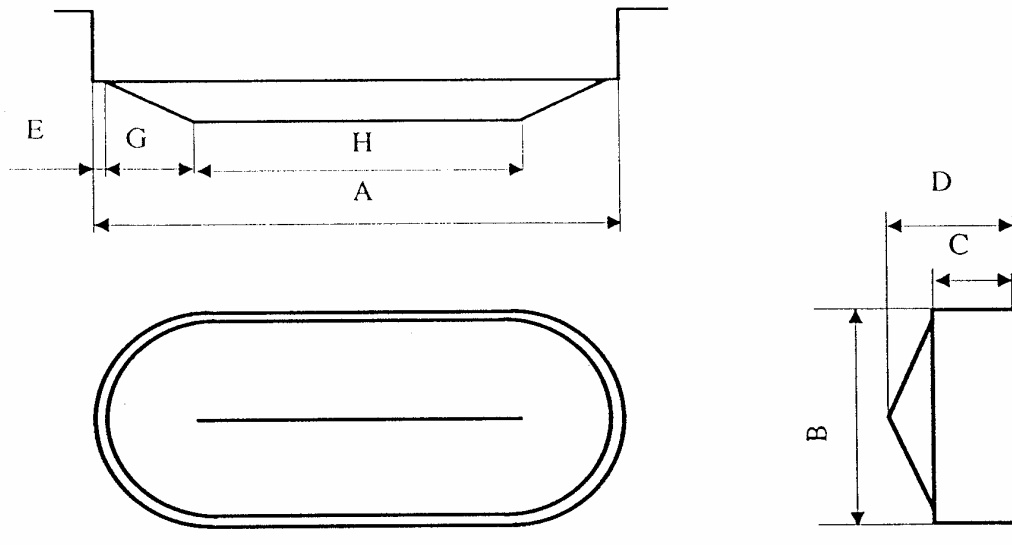
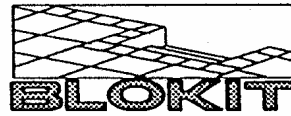

	A	B	C	D	E	G	H
OV I	7,7	3,95	1,06	1,4	0,2	1,775	3,75
OV II	8,7	3,95	1,06	1,4	0,2	1,775	4,75
OV III	9,65	4,9	1,06	1,5	0,2	2,25	4,75
OV IV	11,7	5,7	1,06	1,5	0,2	2,65	6

## TECHNISCHE ZEICHNUNG

FREIFORMBECKEN  
 OVAL FÜR DACHFÖRMIGEM  
 UNTERGRUND

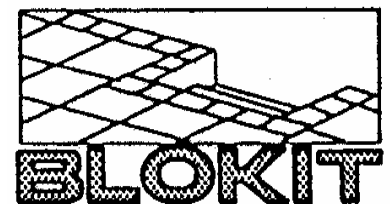

ZEICHNUNG B 060

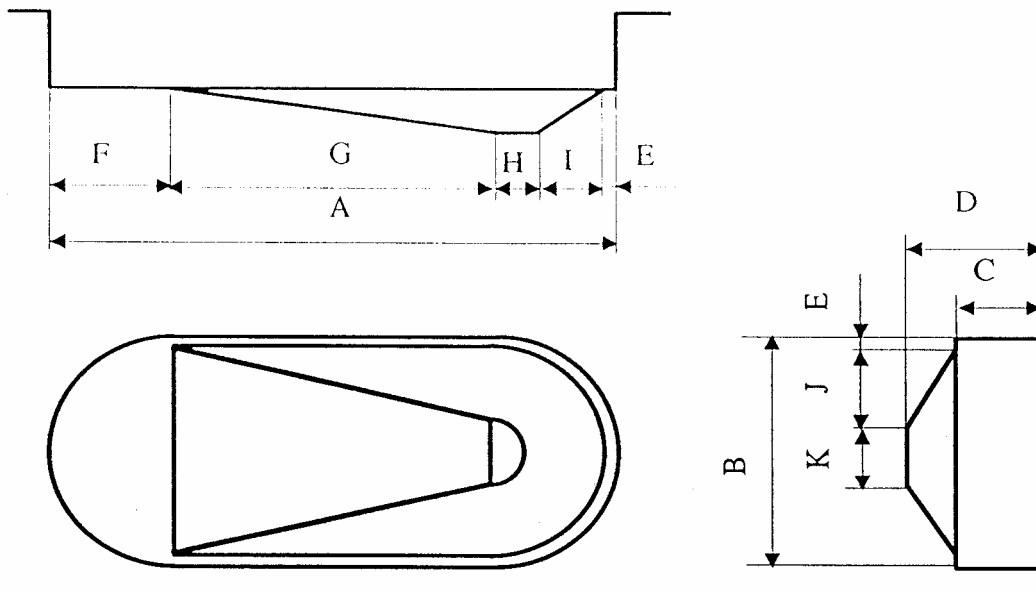
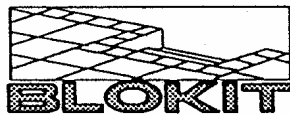

	A	B	C	D	E	F	G	H	I	J	K
OV I	7,7	3,95	1,06	2,1	0,2	1,975	3,75	0,5	1,275	1,275	1
OV II	8,7	3,95	1,06	2,1	0,2	1,975	4,75	0,5	1,275	1,275	1
OV III	9,65	4,9	1,06	2,2	0,2	2,45	4,75	0,5	1,75	1,75	1
OV IV	11,7	5,7	1,06	2,2	0,2	2,85	6	1	1,65	1,65	2

# TECHNISCHE ZEICHNUNG

FREIFORMBECKEN  
 OVAL  
 PYRAMIDENSTUMPF

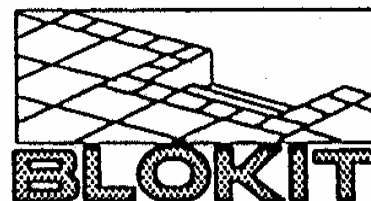

ZEICHNUNG B 061

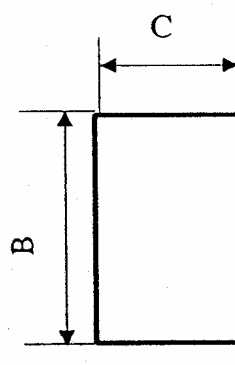
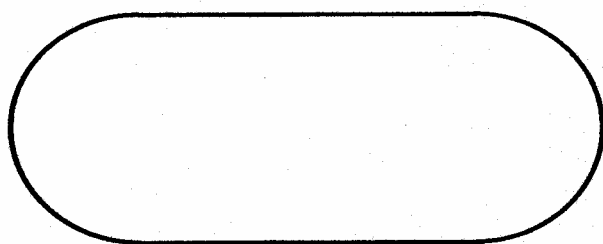
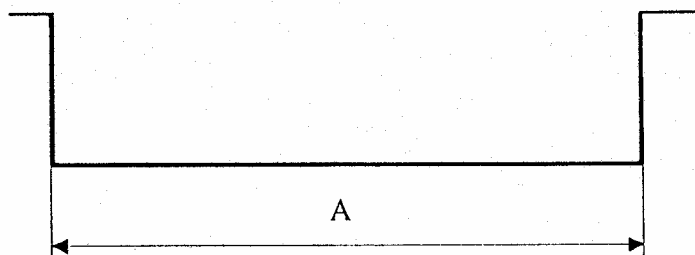
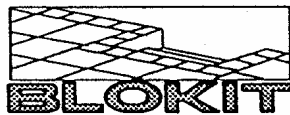

	A	B	C
OVI	7,7	3,95	1,5
OV II	8,7	3,95	1,5
OV III	9,65	4,9	1,5
OV IV	11,7	5,7	1,5

## TECHNISCHE ZEICHNUNG

FREIFORMBECKEN  
 OVALE FORM MIT  
 FLACHEM UNTERGRUND 1,50

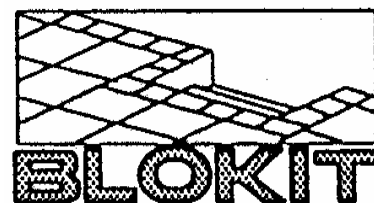

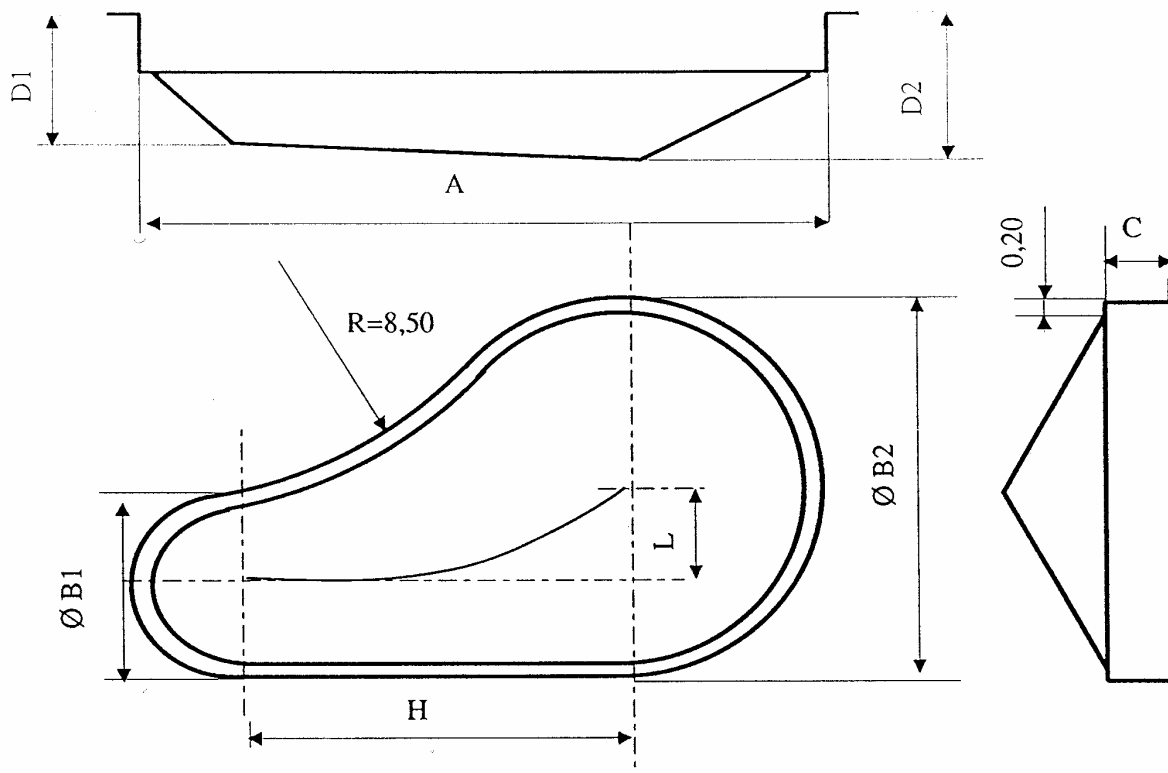
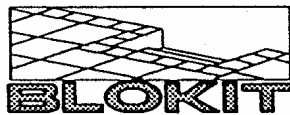

	A	B1	B2	C	D1	D2	H	L
KIDNEY I	11,3	4,9	5,7	1,5	1,4	1,5	0,4	6
KIDNEY II	12,25	5,7	6,8	1,5	1,5	1,6	0,55	6

**TECHNISCHE ZEICHNUNG**

**FREIFORMBECKEN  
KIDNEY  
MIT DACHFÖRMIGEM UNTERGRUND**

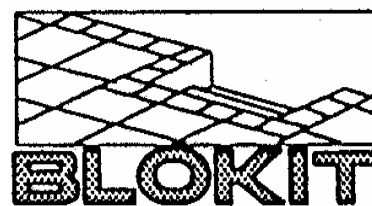

**ZEICHNUNG B 070**

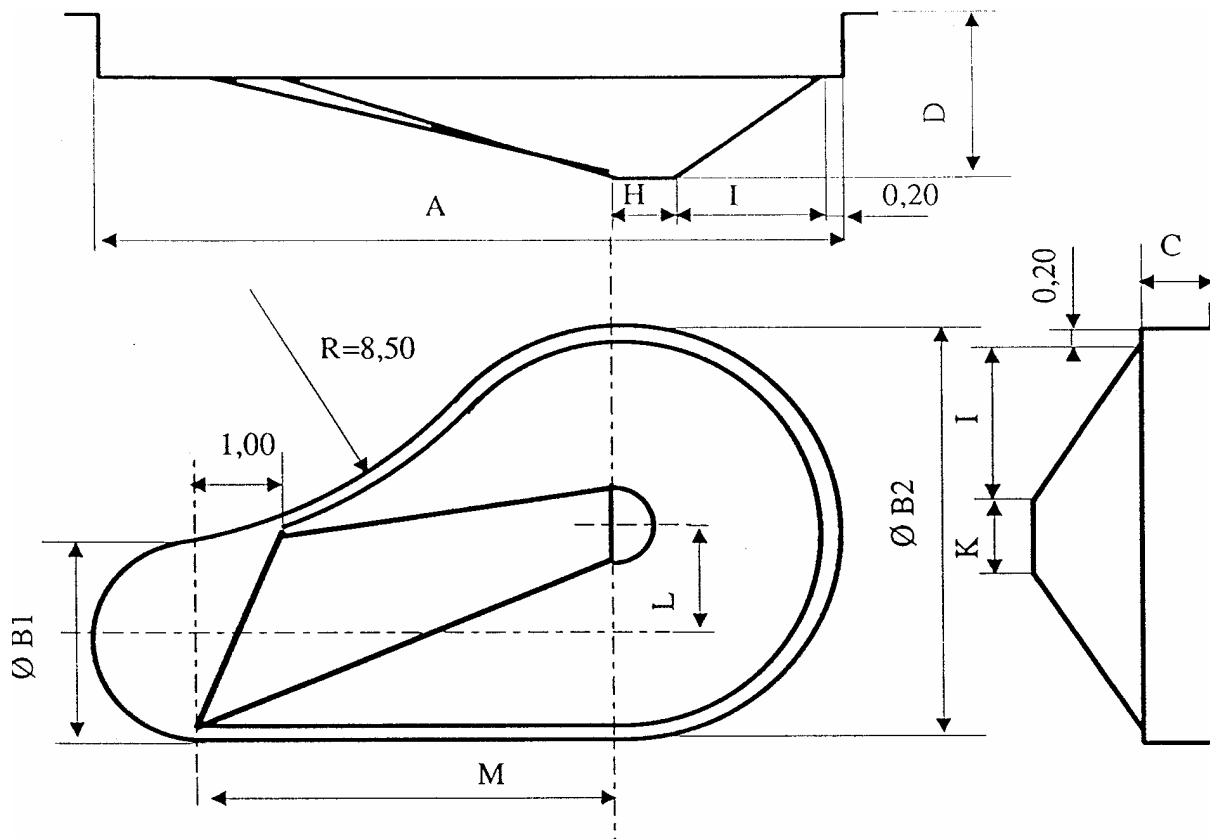
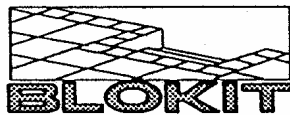

	A	B1	B2	C	D	H	I	K	L	M
KIDNEY I	11,3	4,9	5,7	1,06	2,2	0,5	2,15	1	0,4	6
KIDNEY II	12,25	5,7	6,8	1,06	2,3	0,5	2,7	1	0,55	6

## TECHNISCHE ZEICHNUNG

FREIFORMBECKEN  
 „KIDNEY“  
 PYRAMIDENSTUMPF

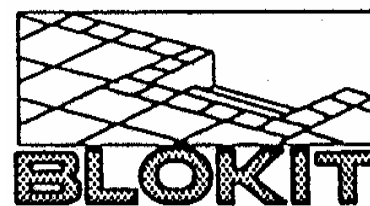

ZEICHNUNG B 071



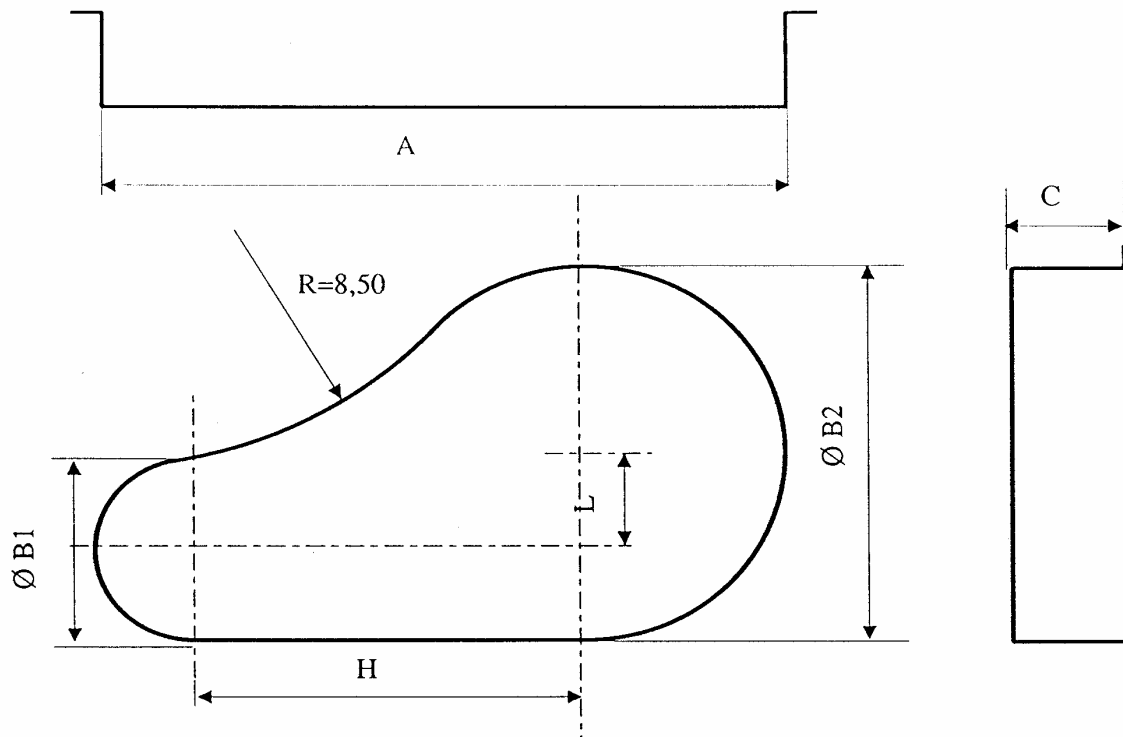
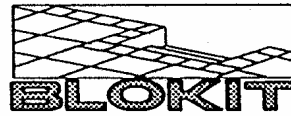

	A	B1	B2	C	L	H
KIDNEY I	11,3	4,9	5,7	1,5	0,4	6
KIDNEY II	12,25	5,7	6,8	1,5	0,55	6

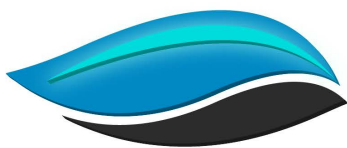

**MYPOOLDIRECT**  
Swimming Pool & Enclosure European Distributor

UK SALES OFFICE: +44 (0) 1268 710425

## TECHNISCHE ZEICHNUNG

FREIFORMBECKEN  
„KIDNEY“  
FLACHER UNTERGRUND 150

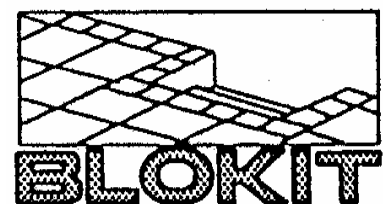

ZEICHNUNG B 072

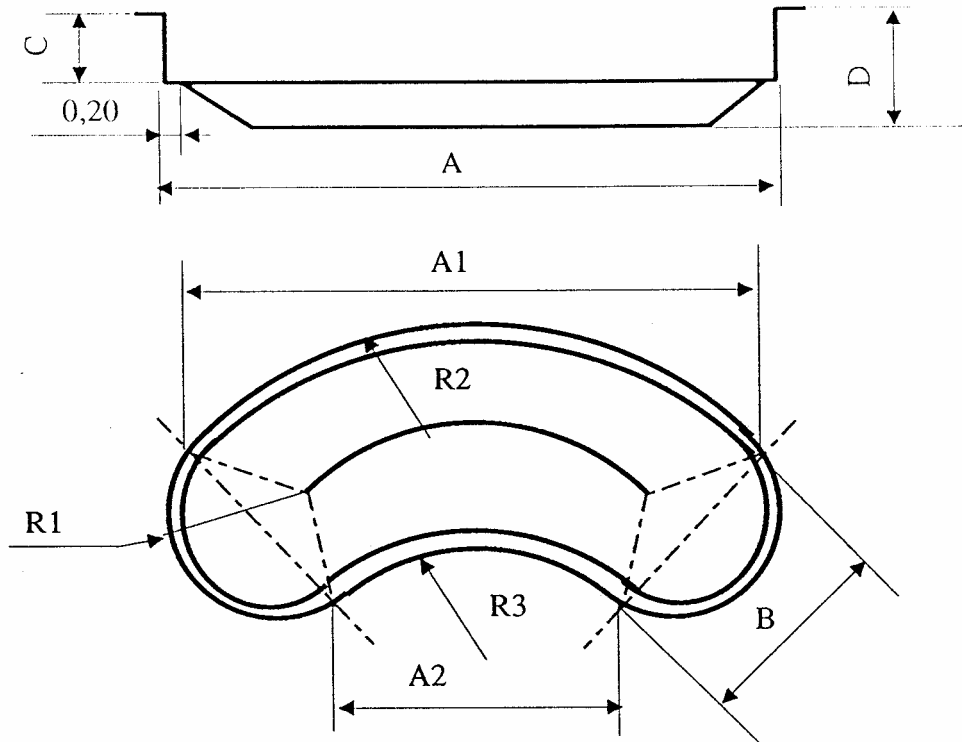
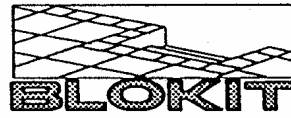

	A	A1	A2	B	C	D	R1	R2	R3
HARICOT I	10,7	9,5	4,8	4,45	1,06	1,4	2,45	6,35	6,6
HARICOT II	11,9	10,72	4,08	5,55	1,06	1,5	2,85	6,6	6,85

## TECHNISCHE ZEICHNUNG

FREIFORMBECKEN  
 „HARICOT“  
 MIT DACHFÖRMIGEM UNTERGRUND

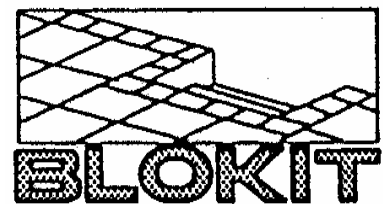

ZEICHNUNG B 080

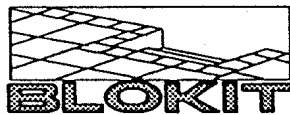

D1

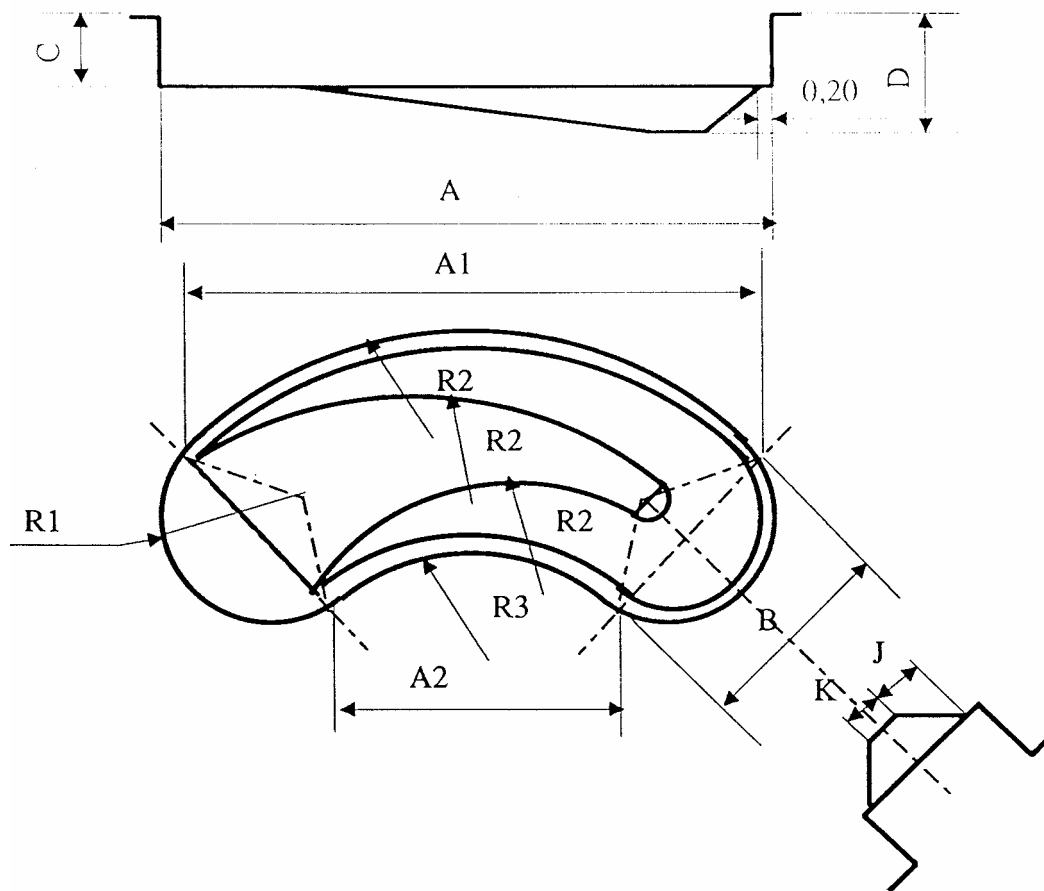

	A	A1	A2	B	C	D	J	K	R1	R2	R3
HARICOT I	10,7	9,5	4,8	4,45	1,06	2,1	1,75	1	2,45	6,35	6,6
HARICOT II	11,9	10,72	4,08	5,55	1,06	2,2	2,15	1	2,85	6,6	6,85

# TECHNISCHE ZEICHNUNG

FREIFORMBECKEN  
HARICOT  
PYRAMIDENSTUMPF

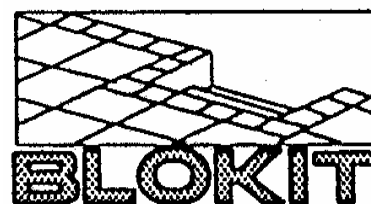

ZEICHNUNG B 081

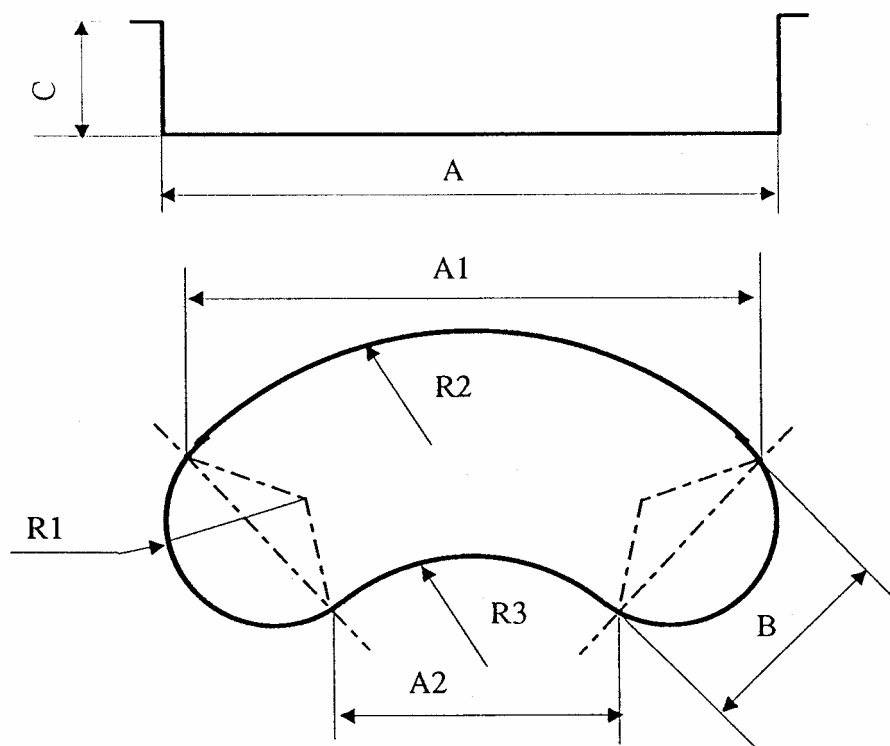
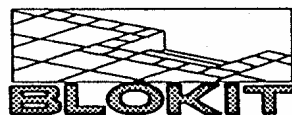

	A	A1	A2	B	C	R1	R2	R3
HARICOT I	10,7	9,5	4,8	4,45	1,5	2,45	6,35	6,6
HARICOT II	11,9	10,72	4,08	5,55	1,5	2,85	6,6	6,85

## TECHNISCHE ZEICHNUNG

FREIFORMBECKEN  
HARICOT  
FLACHER UNTERGRUND 150

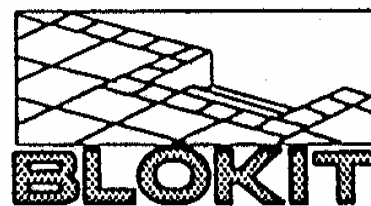

ZEICHNUNG B 082

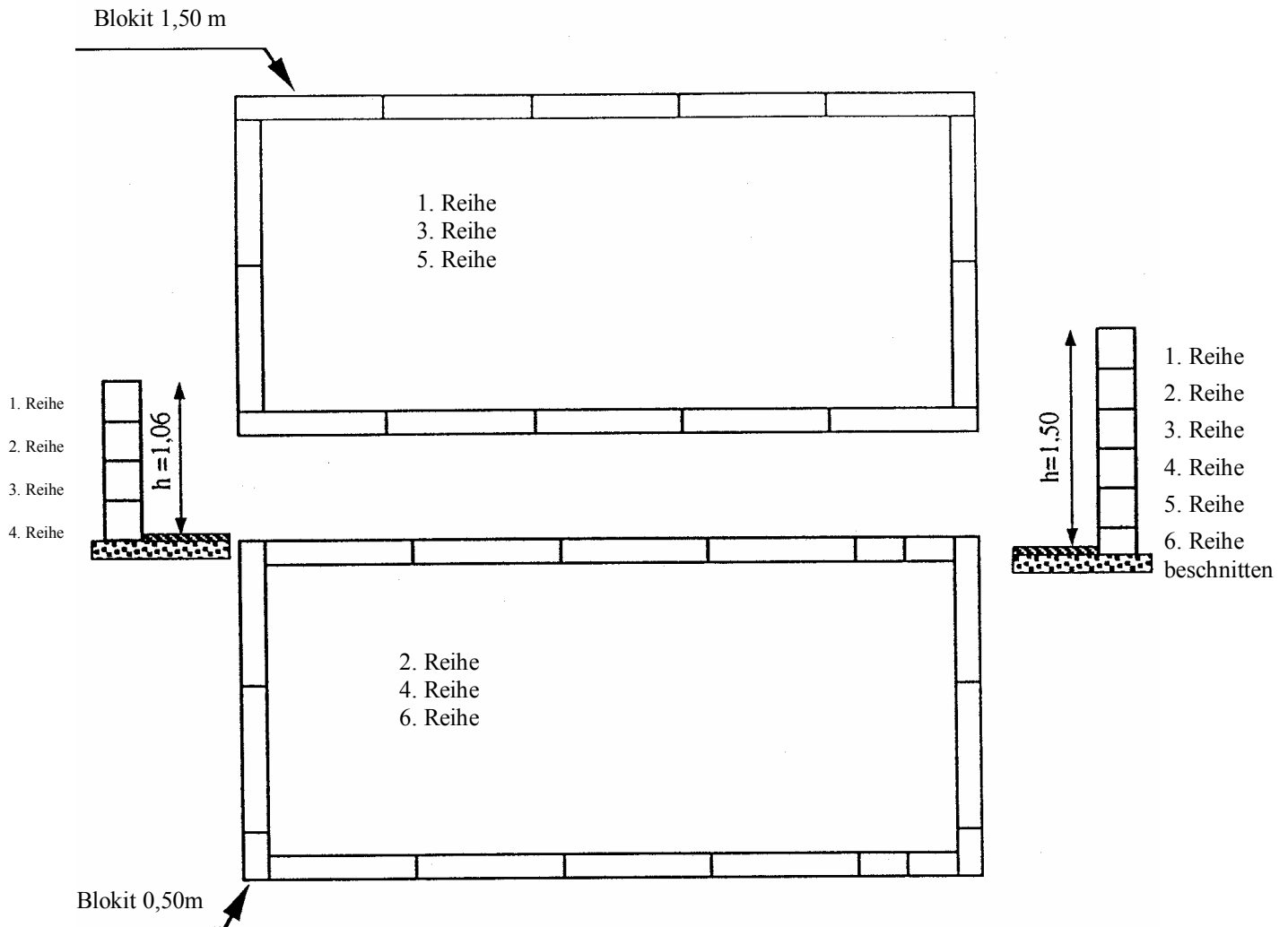
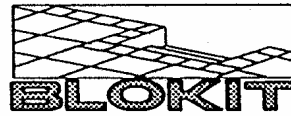

		Pyramidenstumpf	Flacher Untergrund 150
3300200	Blokit 1,50 m	52	66
3301000	Blokit 0,50 m	12	12
3320200	Blokit 1,50, beschnitten	-	12
3320100	Blokit 0,50, beschnitten	-	6
3340200	Stopper H und B	16	24
3360200	Polyester 1,04 x 1,34	15	-
3360400	Polyester 1,48 x 1,34	-	15
3360900	Kleber für Hülle	2	3
3350400	Hung, gerade	20	20
3360600	Schutzhülle außen, H=1,34	22	-
3360700	Schutzhülle außen, H=1,70	-	22

## TECHNISCHE ZEICHNUNG

### DETAILZEICHNUNG

7x3

### PYRAMIDENSTUMPF und FLACHER UNTERGRUND 150

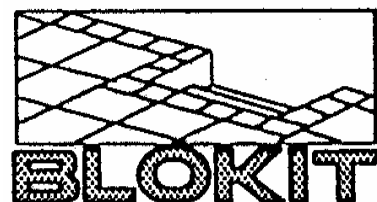

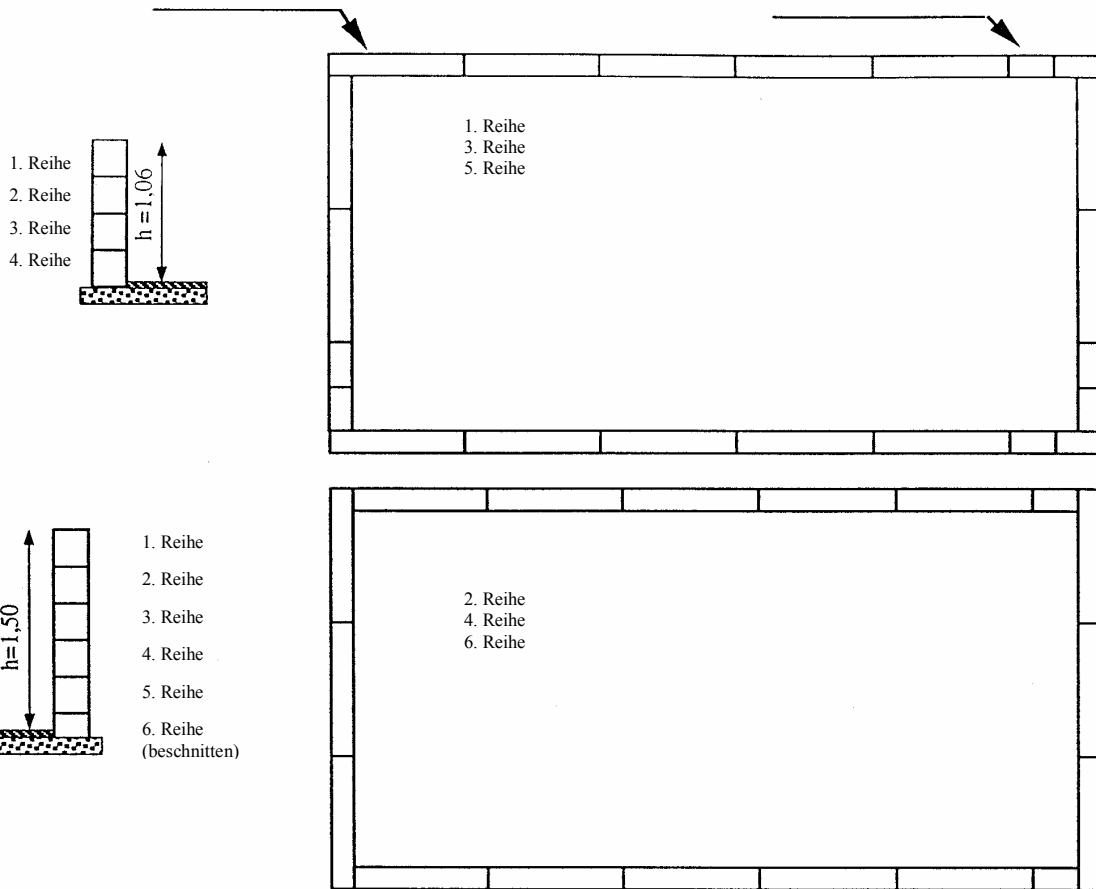
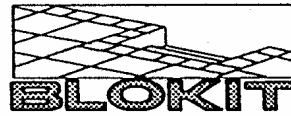

		Pyramidenstumpf	Flacher Untergrund150
3300200	Blokit 1,50 m	60	74
3301000	Blokit 0,50 m	20	28
3320200	Blokit 1,50, beschnitten	-	16
3320100	Blokit 0,50, beschnitten	-	2
3340200	Stopper H und B	16	24
3360200	Polyester 1,04 x 1,34	18	-
3360400	Polyester 1,48 x 1,34	-	18
3360900	Kleber für Hülle	2	3
3350400	Hung, gerade	24	24
3360600	Schutzhülle außen, H=1,34	26	-
3360700	Schutzhülle außen, H=1,70	-	26

## TECHNISCHE ZEICHNUNG

### DETAILZEICHNUNG

8 x 4

### PYRAMIDENSTUMPF und FLACHER UNTERGRUND 150

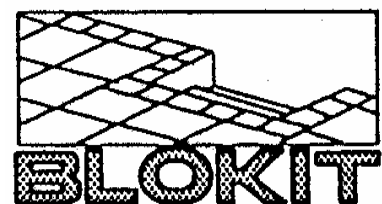

ZEICHNUNG B 101

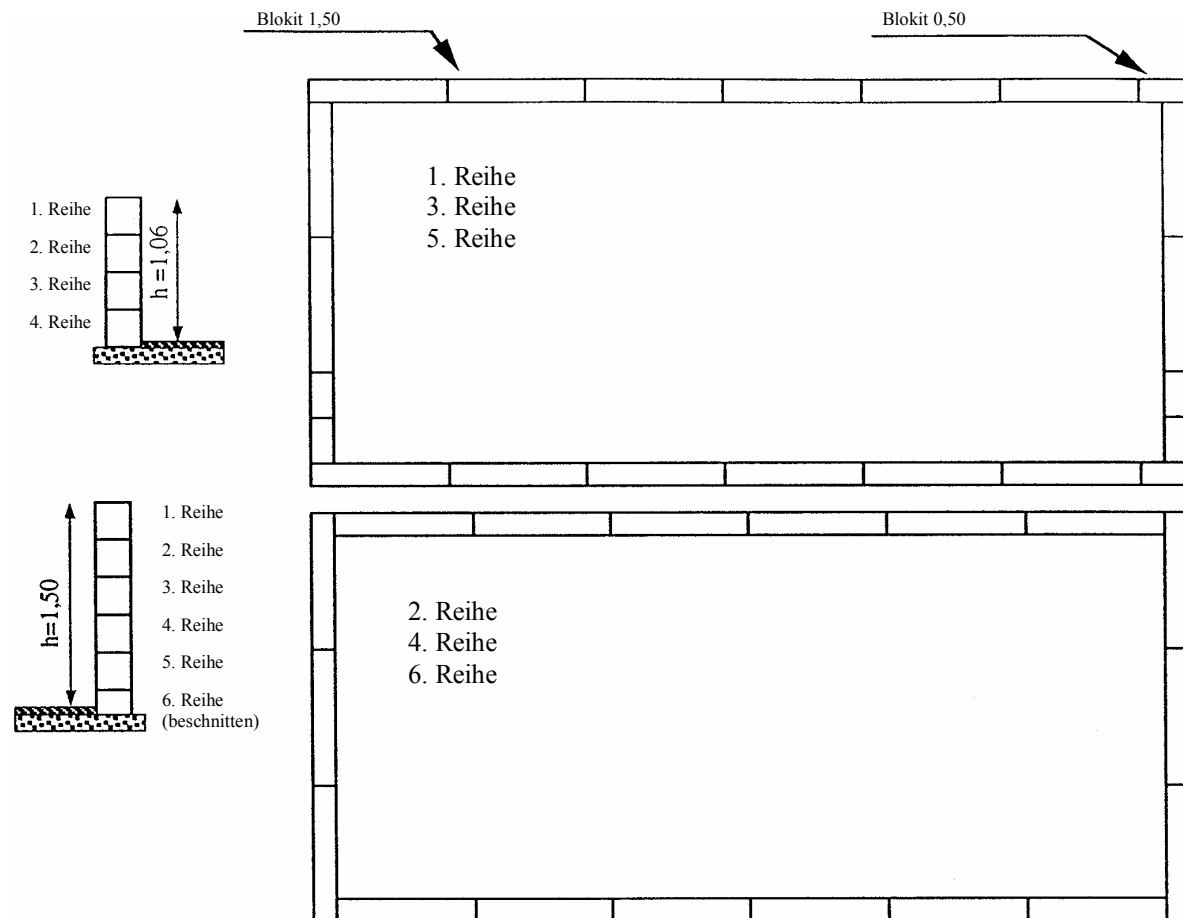
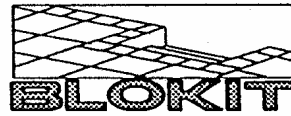

		Pyramidenstumpf	Flacher Untergrund150
3300200	Blokkit 1,50 m	68	84
3301000	Blokkit 0,50 m	12	18
3320200	Blokkit 1,50, beschnitten	-	18
3320100	Blokkit 0,50, beschnitten	-	-
3340200	Stopper H und B	16	24
3360200	Polyester 1,04 x 1,34	20	-
3360400	Polyester 1,48 x 1,34	-	20
3360900	Kleber für Hülle	2	3
3350400	Hung, gerade	26	26
3360600	Schutzhülle außen, H=1,34	28	-
3360700	Schutzhülle außen, H=1,70	-	28

## TECHNISCHE ZEICHNUNG

### DETAILZEICHNUNG

9 x 4

### PYRAMIDENSTUMPF und FLACHER UNTERGRUND 150

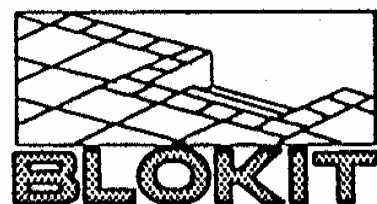

ZEICHNUNG B 102

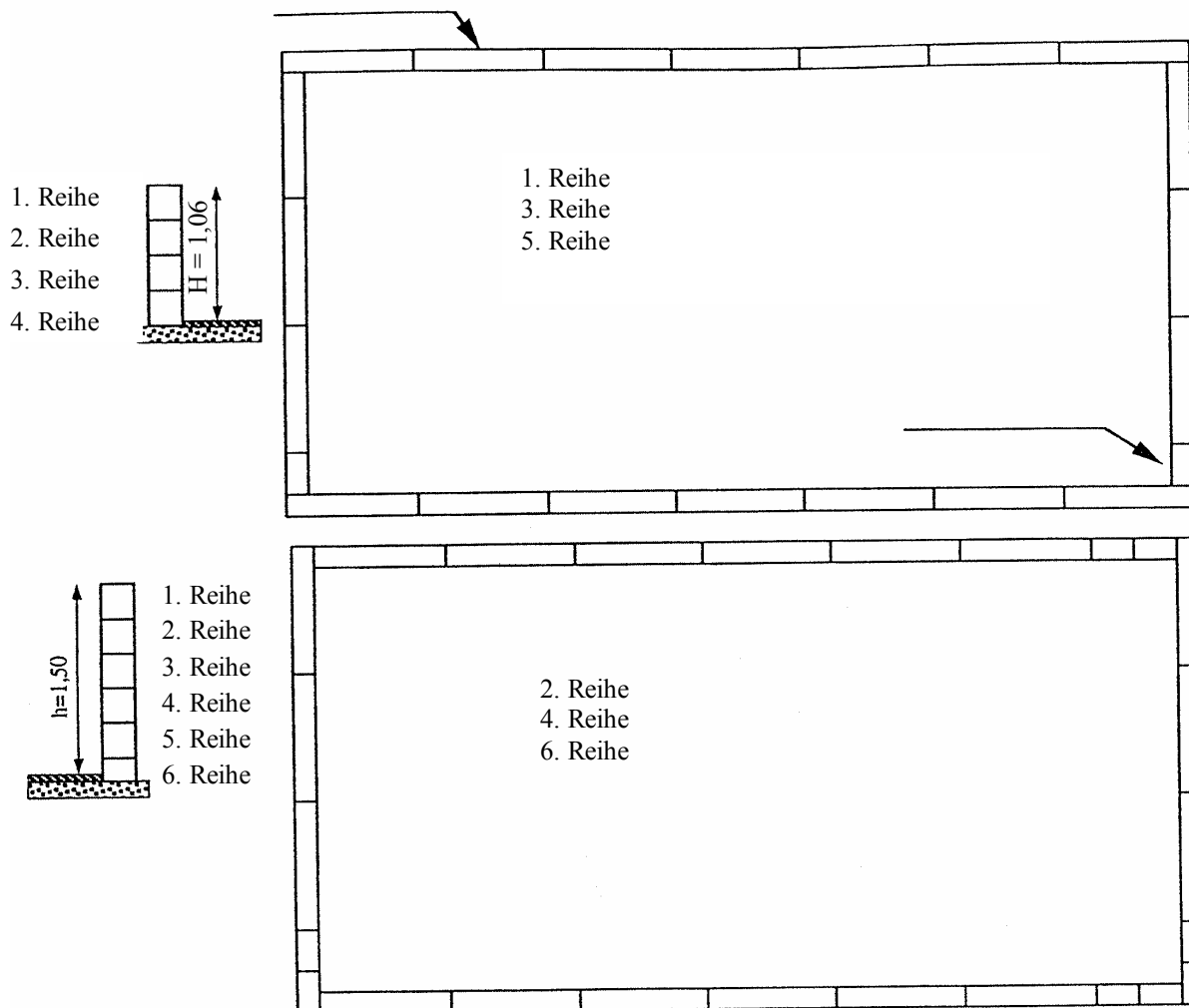
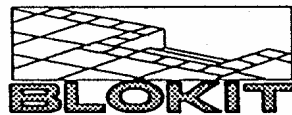

		Pyramidenstumpf	Flacher Untergrund150
3300200	Blokit 1,50 m	76	96
3301000	Blokit 0,50 m	20	22
3320200	Blokit 1,50, beschnitten	-	18
3320100	Blokit 0,50, beschnitten	-	8
3340200	Stopper H und B	16	24
3360200	Polyester 1,04 x 1,34	23	-
3360400	Polyester 1,48 x 1,34	-	23
3360900	Kleber für Hülle	3	4
3350400	Folienauskl. Hung, gerade	30	30
3360600	Schutzhülle außen, H=1,34	32	-
3360700	Schutzhülle außen, H=1,70	-	32

# TECHNISCHE ZEICHNUNG

## DETAILZEICHNUNG

10 x 5

### PUMPENSTUMPF und FLACHER UNTERGRUND 150

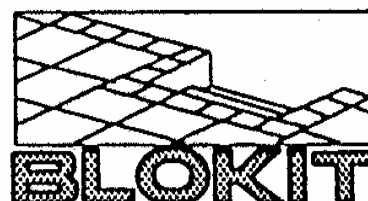



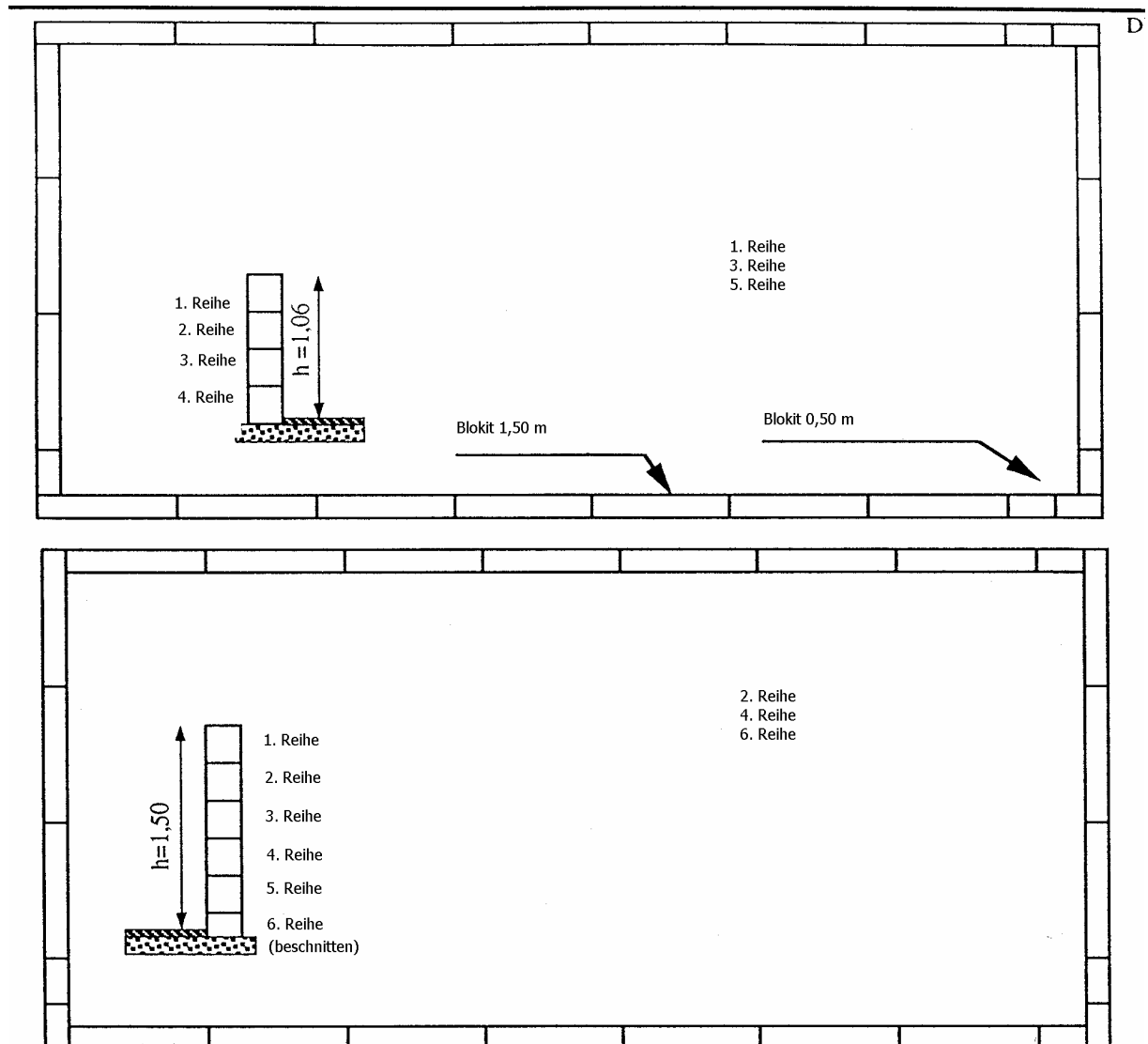
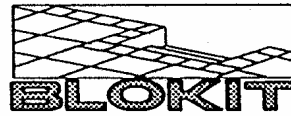

		Pyramidenstumpf	Flacher Untergrund 150
3300200	Blok 1,50 m	80	100
3301000	Blok 0,50 m	24	30
3320200	Blok 1,50, beschnitten	-	20
3320100	Blok 0,50, beschnitten	-	6
3340200	Stopper H und B	16	24
3360200	Polyester 1,04 x 1,34	24	-
3360400	Polyester 1,48 x 1,34	-	24
3360900	Kleber für Hülle	3	4
3350400	Hung, gerade	32	32
3360600	Schutzhülle außen, H=1,34	34	-
3360700	Schutzhülle außen, H=1.70	-	34

## TECHNISCHE ZEICHNUNG

### DETAILZEICHNUNG

11 x 5

PUMPENSTUMPF und FLACHER  
UNTERGRUND 150

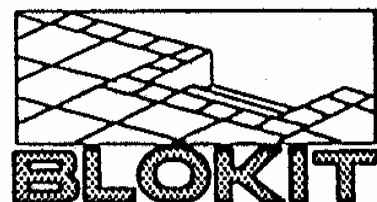

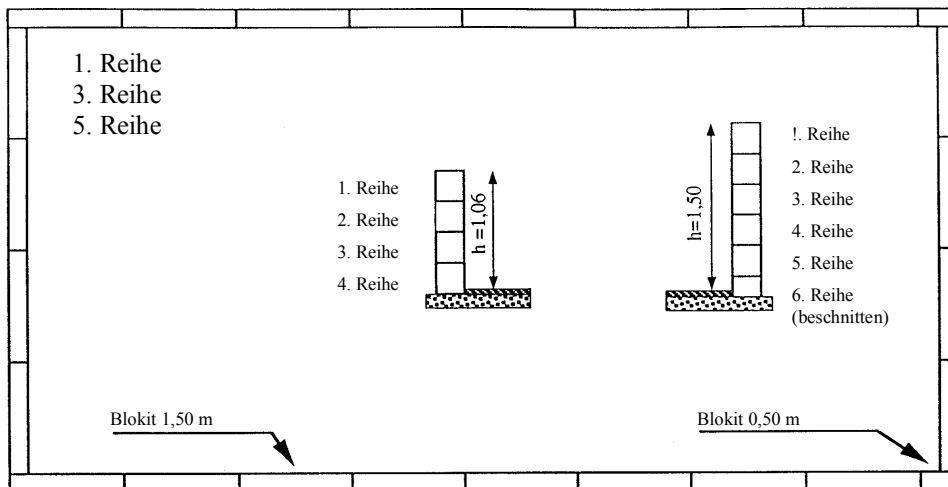
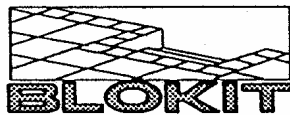

2. Reihe  
4. Reihe  
6. Reihe

		Pyramidenstumpf	Flacher Untergrund 150
3300200	Blokit 1,50 m	96	120
3301000	Blokit 0,50 m	8	10
3320200	Blokit 1,50, beschnitten	-	24
3320100	Blokit 0,50, beschnitten	-	2
3340200	Stopper H und B	16	24
3360200	Polyester 1,04 x 1,34	27	-
3360400	Polyester 1,48 x 1,34	-	27
3360900	Kleber für Hülle	4	4
3350400	Hung, gerade	36	36
3360600	Schutzhülle außen, H=1,34	38	-
3360700	Schutzhülle außen H=1 70	-	38

# TECHNISCHE ZEICHNUNG

## DETAILZEICHNUNG

12 x 6

### PYRAMIDENSTUMPF und FLACHER UNTERGRUND 150

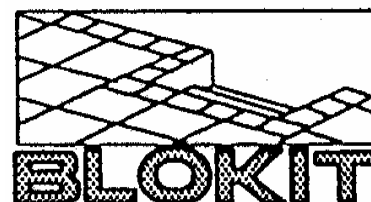

ZEICHNUNG B 105

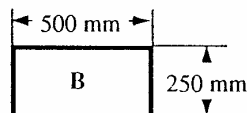
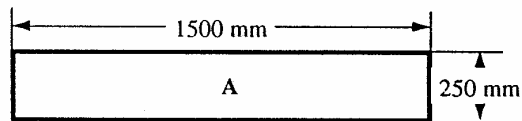
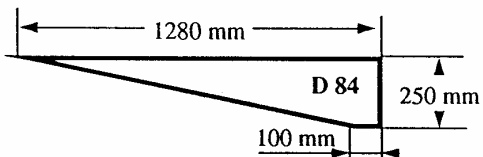
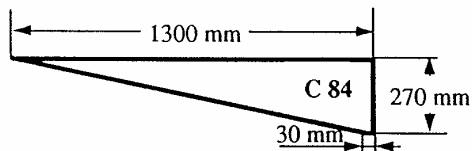
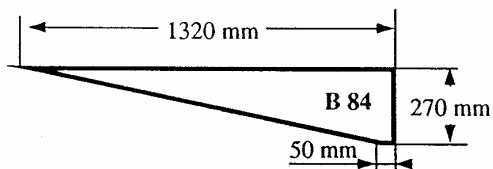
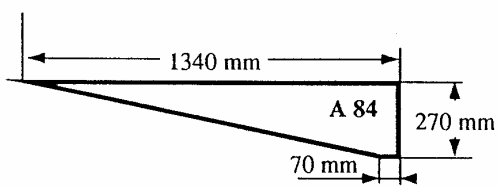
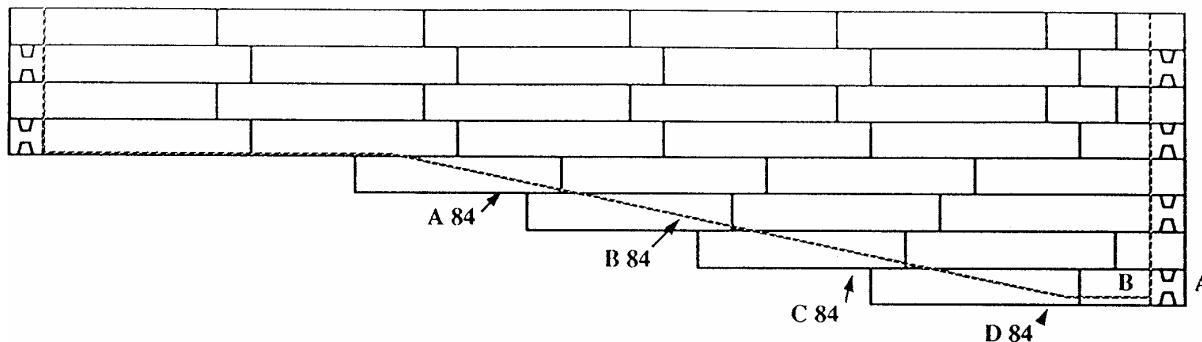
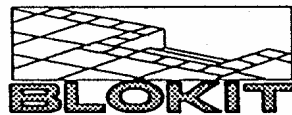

3350400	Hung gerade	24
3360900	Kleber für Hülle	3
3360200	Polyester 1,04 x 1,34	18
3360600	Außenhülle H = 1,34	37
3340200	Stopper H und B	24
3300200	Blokít 1,50	79
3301000	Blokít 0,50	26
	D 84	2
	C 84	2
	B 84	2
	A 84	2
	B	2
	A	3
	Bezeichnung	Anzahl

Schneidwinkel = 12°

## TECHNISCHE ZEICHNUNG

UNTERGRUND MIT SCHRÄGE

8 x 4

DETAILZEICHNUNG

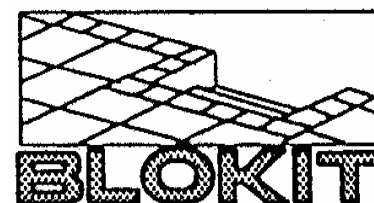

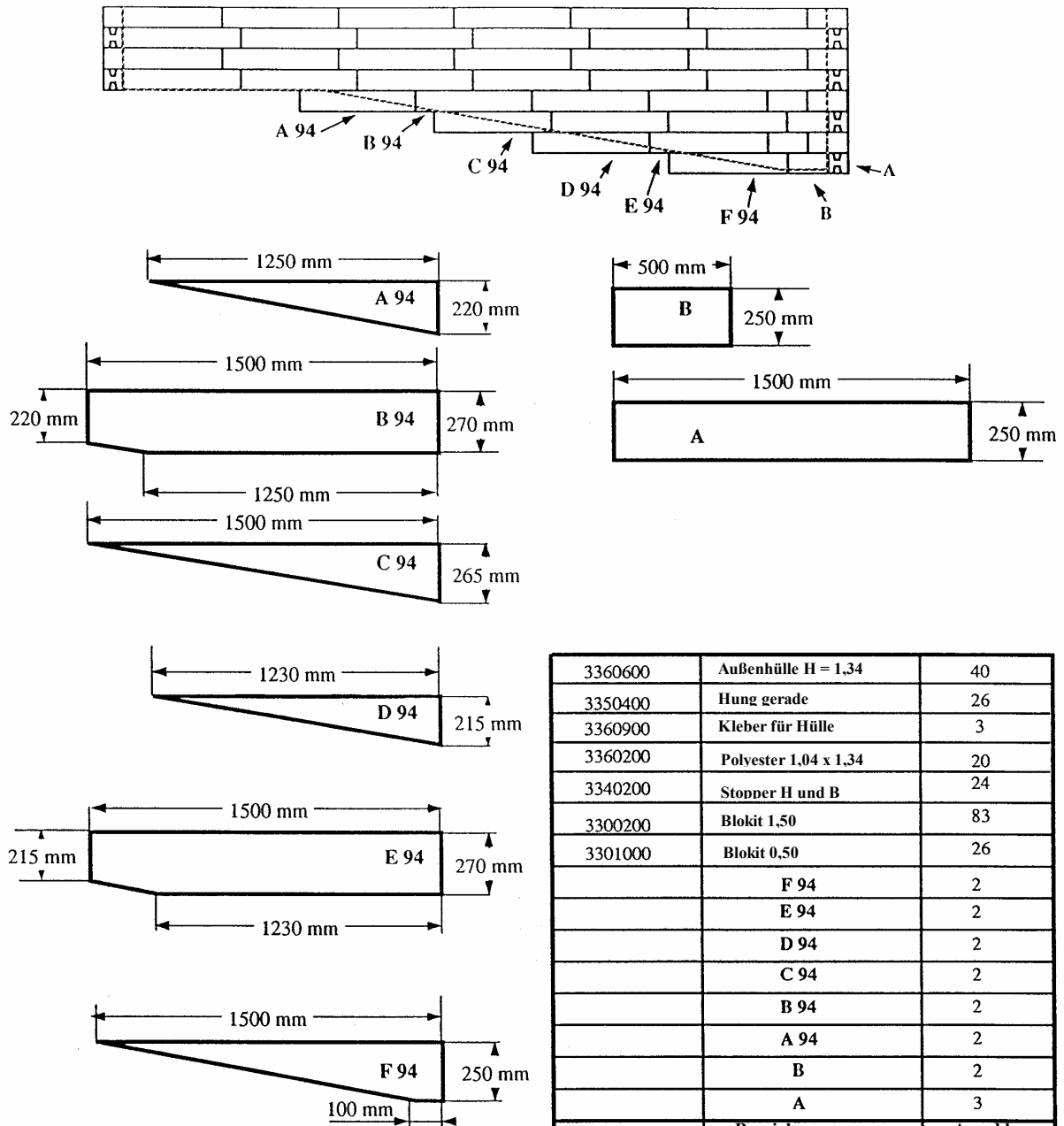
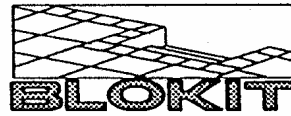

3360600	Außenhülle H = 1,34	40
3350400	Hung gerade	26
3360900	Kleber für Hülle	3
3360200	Polvester 1,04 x 1,34	20
3340200	Stopper H und B	24
3300200	Blokitt 1,50	83
3301000	Blokitt 0,50	26
	F 94	2
	E 94	2
	D 94	2
	C 94	2
	B 94	2
	A 94	2
	B	2
	A	3
	Bezeichnung	Anzahl

Schneidwinkel = 10°

## TECHNISCHE ZEICHNUNG

UNTERGRUND MIT SCHRÄGE

9 x 4

DETAILZEICHNUNG

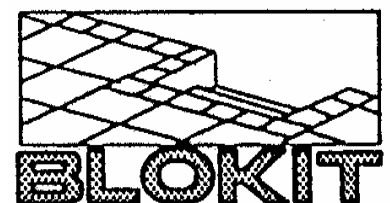

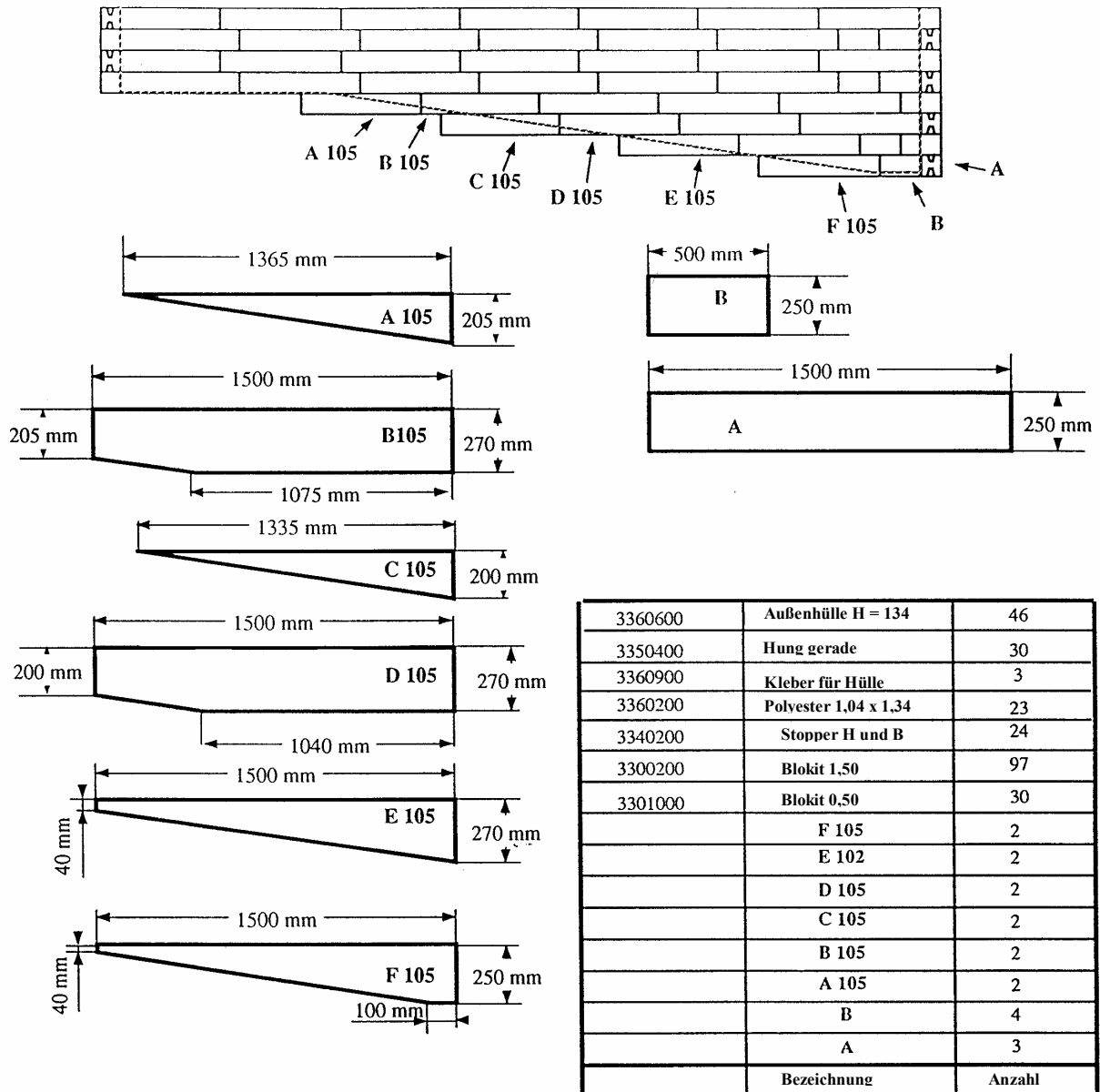
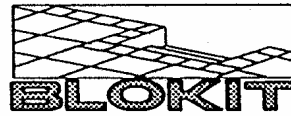

# TECHNISCHE ZEICHNUNG

UNTERGRUND MIT SCHRÄGE

10 x 5

DETAILZEICHNUNG

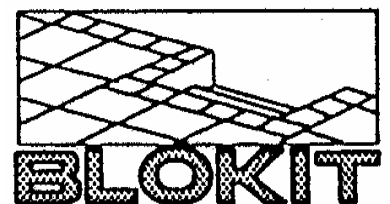

ZEICHNUNG B 112

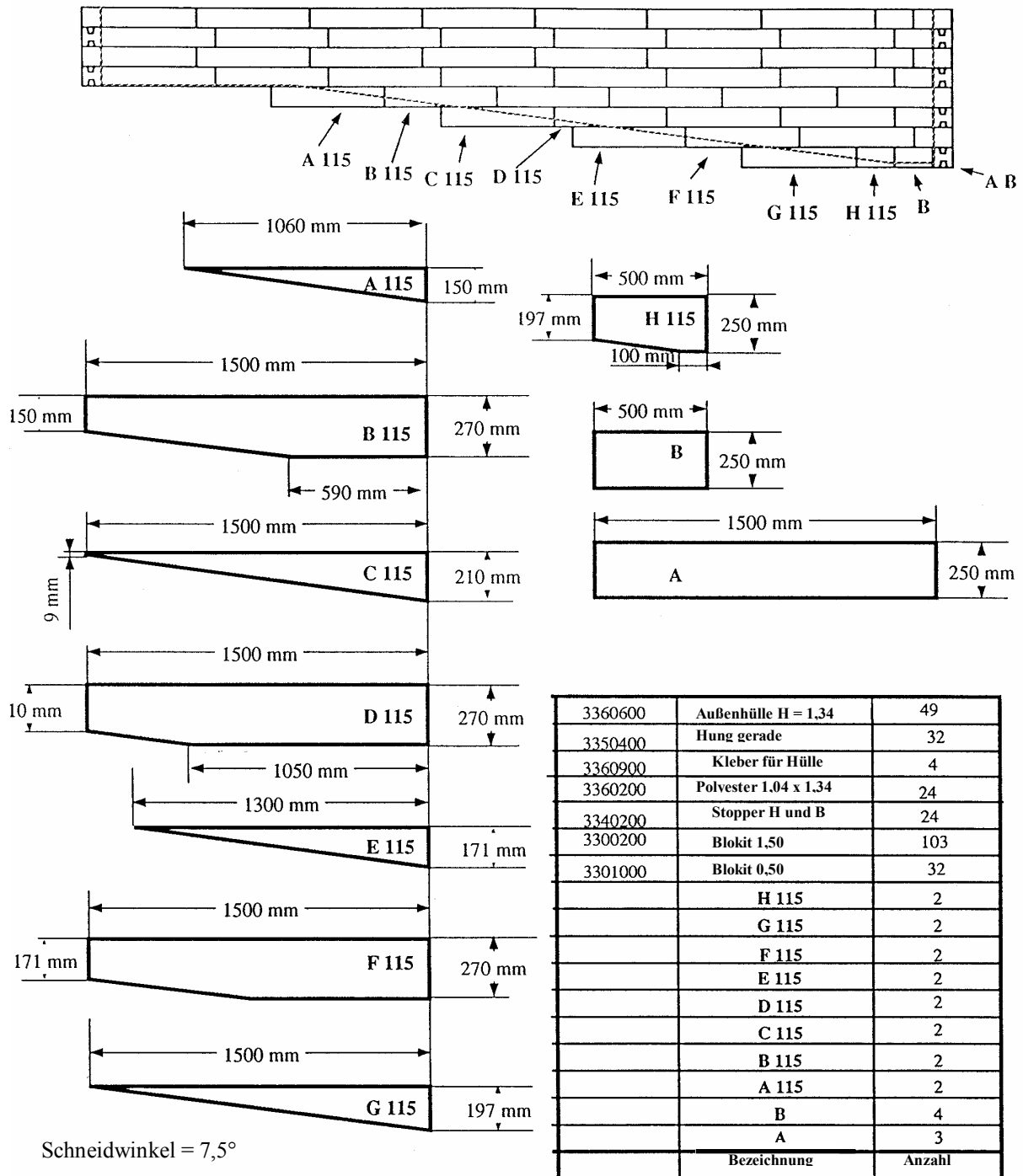
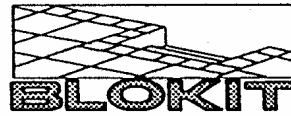

## TECHNISCHE ZEICHNUNG

UNTERGRUND MIT SCHRÄGE  
11 x 5  
DETAILZEICHNUNG

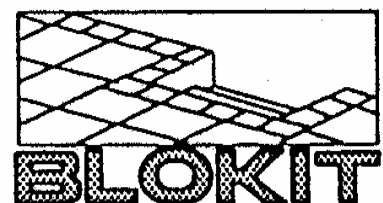

ZEICHNUNG B 113

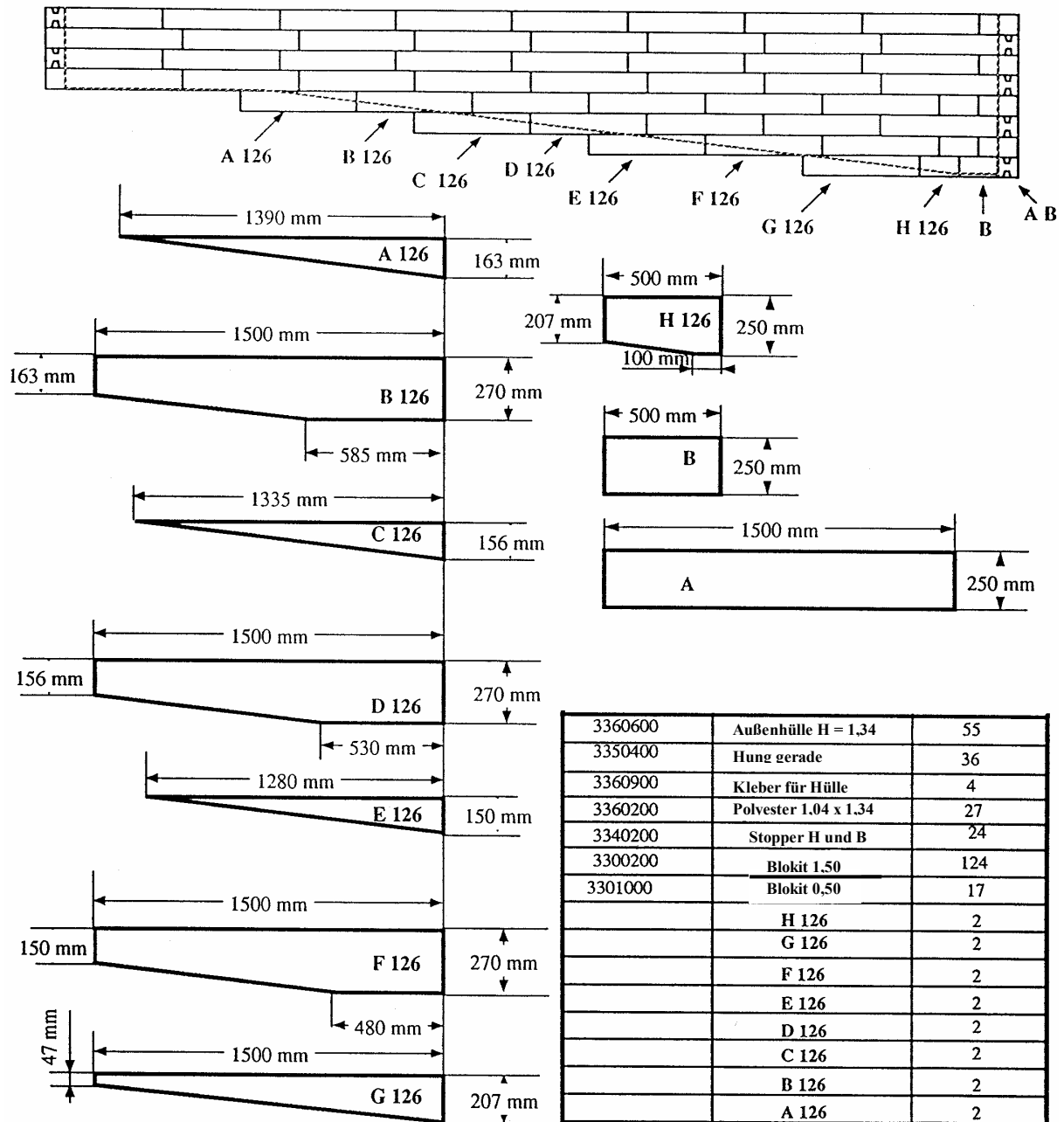
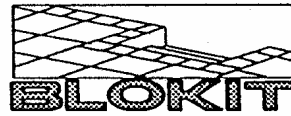

3360600	Außenhülle H = 1,34	55
3350400	Hung gerade	36
3360900	Kleber für Hülle	4
3360200	Polvester 1.04 x 1.34	27
3340200	Stopper H und B	24
3300200	Blokít 1,50	124
3301000	Blokít 0,50	17
	H 126	2
	G 126	2
	F 126	2
	E 126	2
	D 126	2
	C 126	2
	B 126	2
	A 126	2
	B	3
	A	4
	Bezeichnung	Anzahl

Schneidewinkel = 6,5°

**TECHNISCHE ZEICHNUNG**  
**UNTERGRUND MIT SCHRÄGE**  
**12 x 6**  
**DETAILZEICHNUNG**

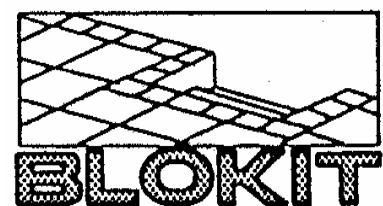

ZEICHNUNG B 114

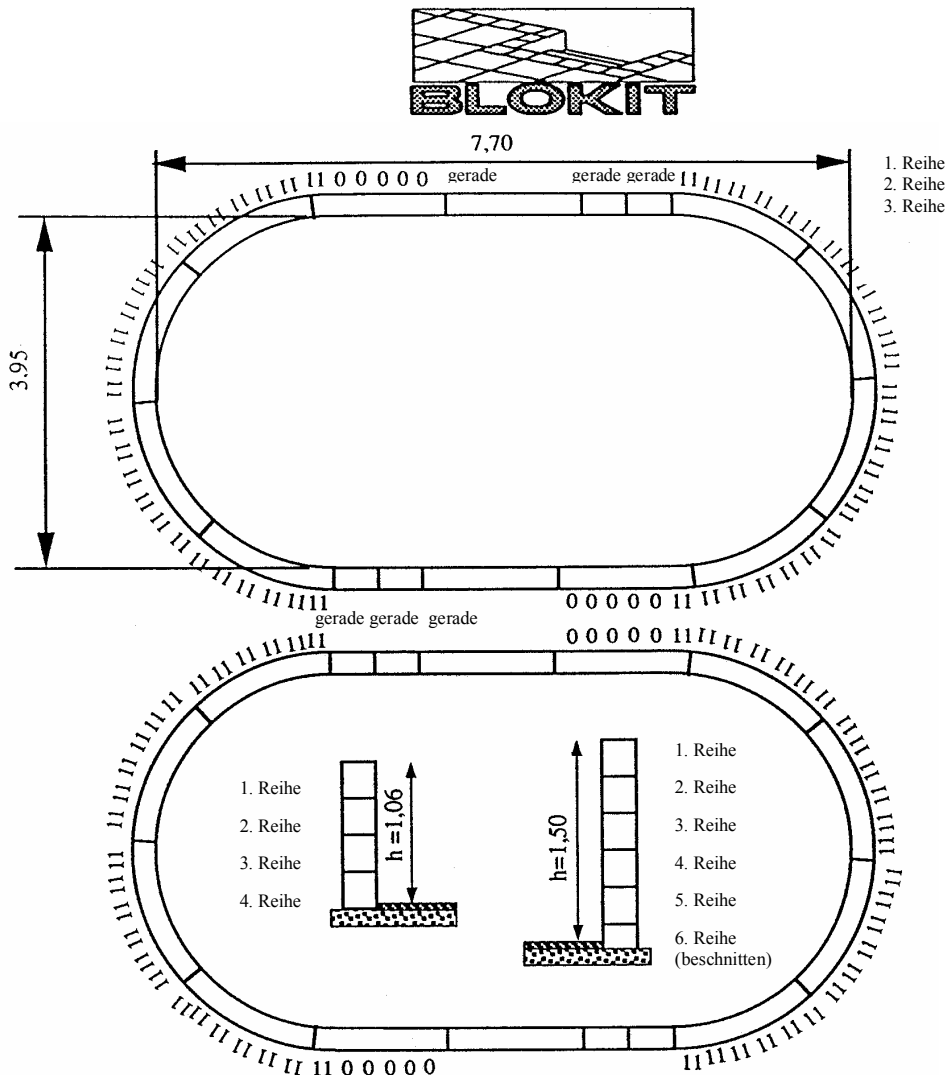

		Pyramidenstumpf	Flacher Untergrund 150
3300200	Blokit 1,50 m	8	10
3301000	Blokit 0,50 m	16	20
3310200	Blokit mit Öffnung 1,50 m	40	50
3320200	Blokit 1,50, beschnitten	-	2
3320100	Blokit 0,50, beschnitten	-	4
3330200	Blokit mit Öffnung 1,50 beschnitten	-	10
3341200	Stopper Nr. 0	40	60
3342400	Stopper Nr. 11	200	300
3350200	Hung gerade(m)	8	8
3350800	Hung gebogen (m)	12	12
3360200	Polyester 1,04 x 1,34	15	-
3360400	Polyester 1,48 x 1,34	-	15
3360900	Kleber für Hülle	2	3
3360600	Schutzhülle außen, H=1,34	22	-
3360700	Schutzhülle außen, H=1,70	-	22

# TECHNISCHE ZEICHNUNG

## DETAILZEICHNUNG OVALES BECKEN I (7,70 x 3,95)

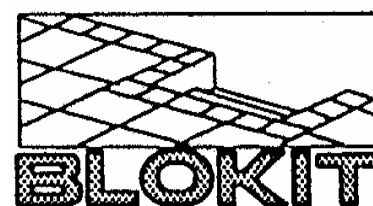



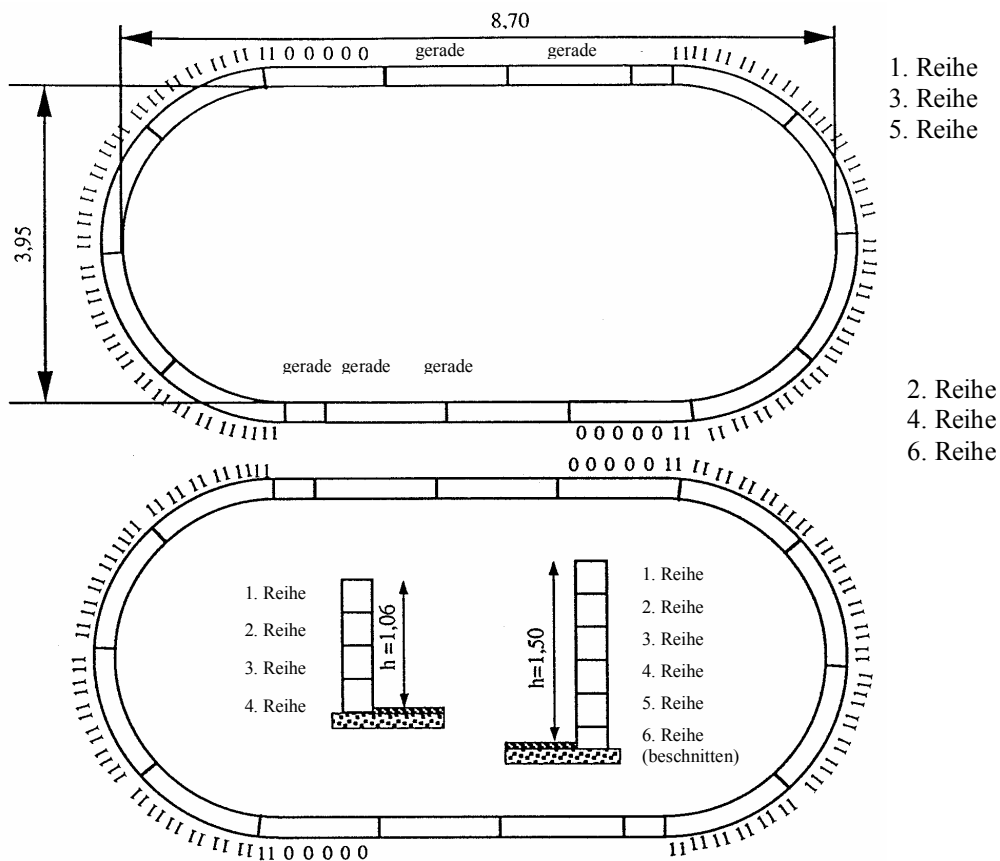
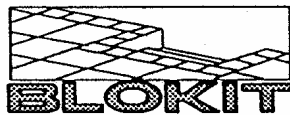

		Pyramidenstumpf	Flacher Untergrund 150
3300200	Blokit 1,50 m	16	20
3301000	Blokit 0,50 m	8	10
3310200	Blokit mit Öffnung 1,50 m	40	50
3320200	Blokit 1,50, beschnitten	-	4
3320100	Blokit 0,50, beschnitten	-	2
3330200	Blokit mit Öffnung 1,50 beschnitten	-	10
3341200	Stopper Nr. 0	40	60
3342400	Stopper Nr. 11	200	300
3350200	Hung gerade(m)	10	10
3350800	Hung gebogen (m)	12	12
3360200	Polyester 1,04 x 1,34	17	-
3360400	Polyester 1,48 x 1,34	-	17
3360900	Kleber für Hülle	2	3
3360600	Schutzhülle außen, H=1,34	24	-
3360700	Schutzhülle außen, H=1,70	-	24

# TECHNISCHE ZEICHNUNG

## DETAILZEICHNUNG OVALES BECKEN II (8,70 x 3,95)

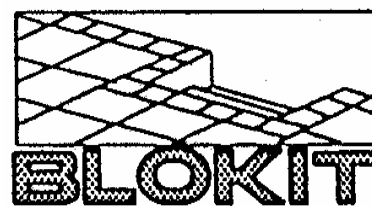

ZEICHNUNG B 121

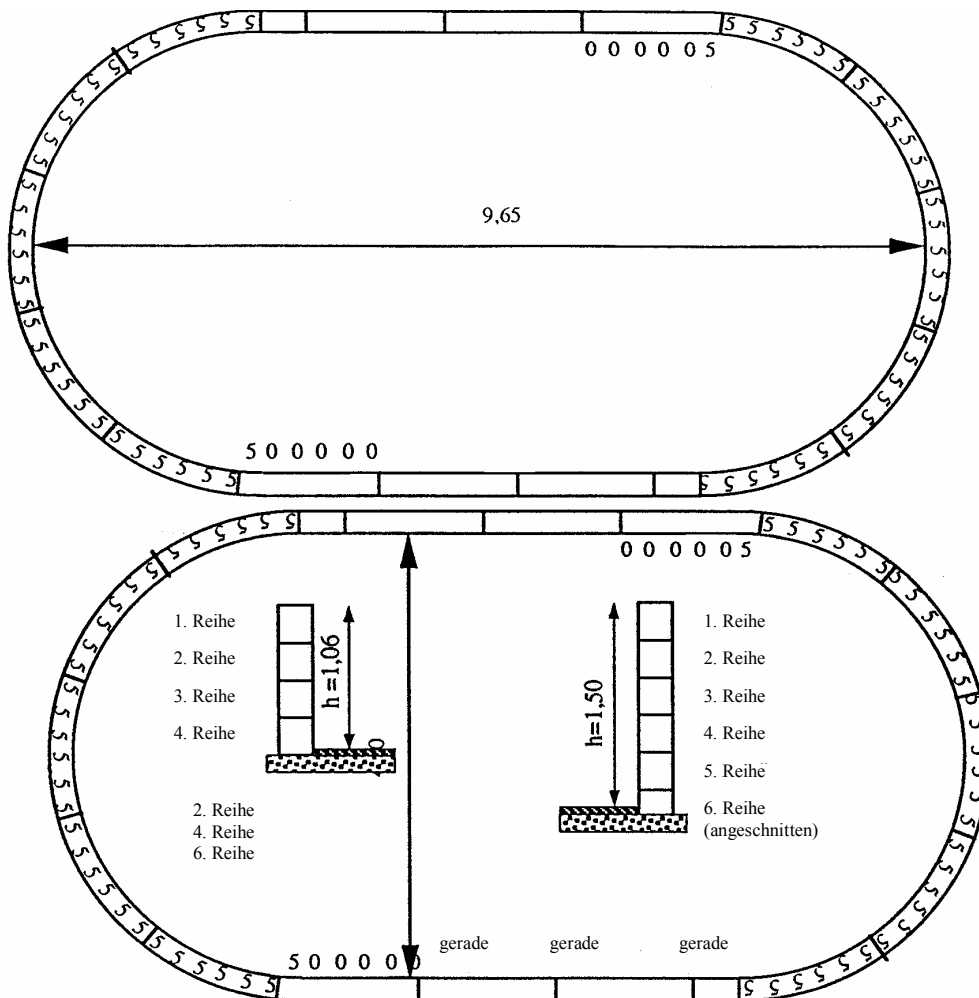
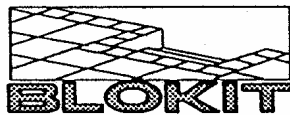

		Pyramidenstumpf	Flacher Untergrund 150
3300200	Blokit 1,50 m	16	20
3301000	Blokit 0,50 m	8	10
3310200	Blokit mit Öffnung 1,50 m	48	60
3320200	Blokit 1,50, beschnitten	-	4
3320100	Blokit 0,50, beschnitten	-	2
3330200	Blokit mit Öffnung 1,50 beschnitten	-	12
3341200	Stopper Nr. 0	40	60
3342200	Stopper Nr. 5	248	372
3350200	Hung gerade(m)	10	10
3350800	Hung gebogen (m)	15	15
3360200	Polyester 1,04 x 1,34	19	-
3360400	Polyester 1,48 x 1,34	-	19
3360900	Kleber für Hülle	3	3
3360600	Schutzhülle außen, H=1,34	28	-
3360700	Schutzhülle außen, H=1,70	-	28

# TECHNISCHE ZEICHNUNG

## DETAILZEICHNUNG OVALES BECKEN III (9,65 x 4,90)

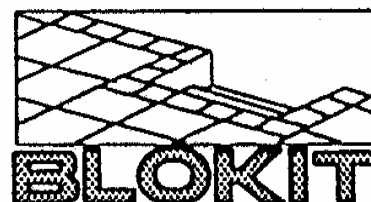

ZEICHNUNG B 122

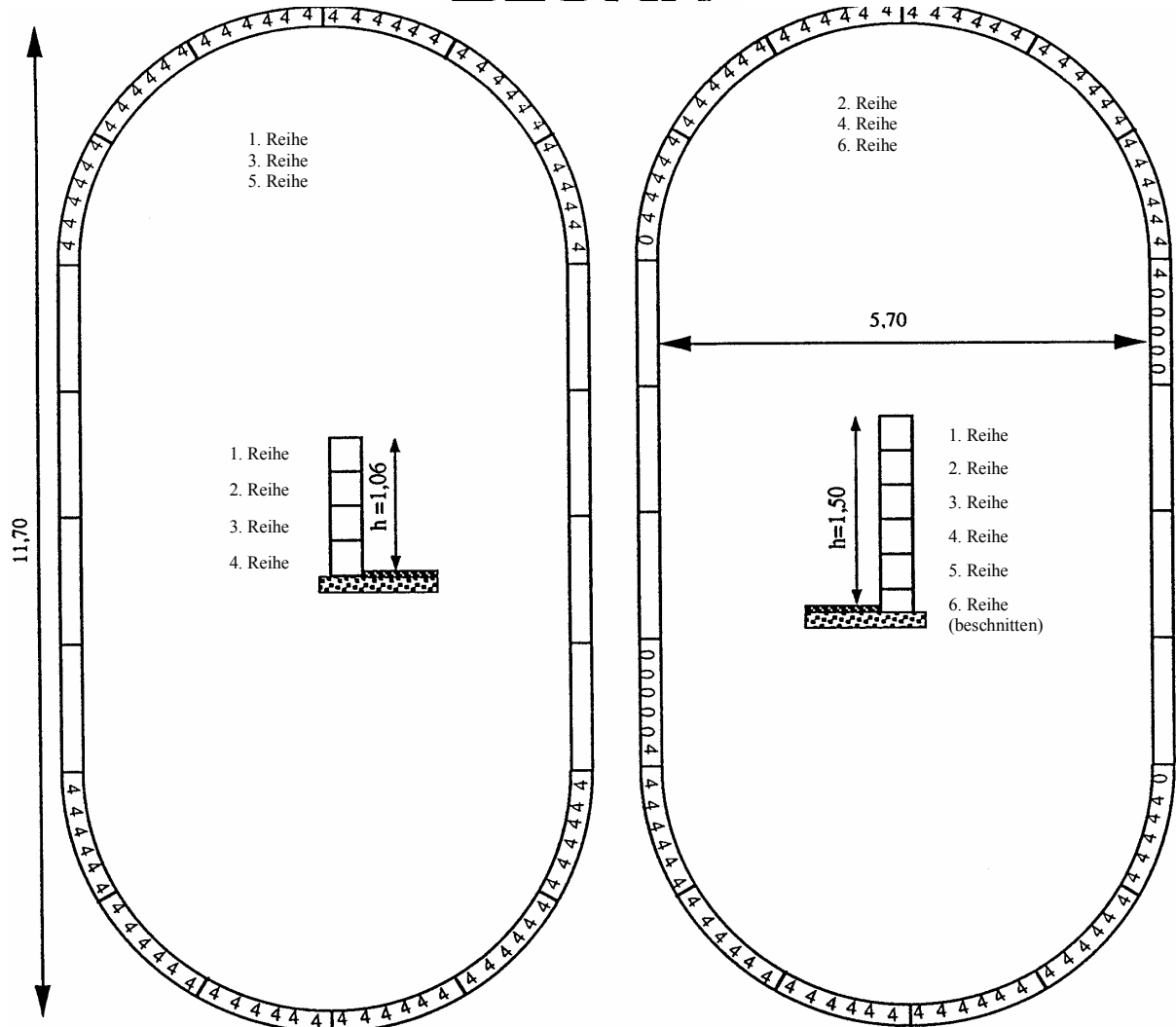
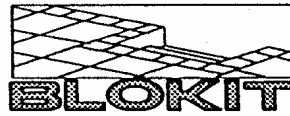

		Pyramidenstumpf	Flacher Untergrund150
3300200	Blokit 1,50 m	28	36
3310200	Blokit mit Öffnung 1,50 m	52	64
3320200	Blokit 1,50, beschnitten	-	4
3330200	Blokit mit Öffnung 1,50 beschnitten	-	14
3341200	Stopper Nr. 0	24	36
3342000	Stopper Nr. 4	288	432
3350200	Befestigungsschiene Hung gerade(m)	12	12
3350800	Hung gebogen (m)	18	18
3360200	Polyester 1,04 x 1,34	23	-
3360400	Polyester 1,48 x 1,34	-	23
3360900	Kleber für Hülle	3	4
3360600	Schutzhülle außen, H=1,34	32	-
3360700	Schutzhülle außen, H=1,70	-	32

# TECHNISCHE ZEICHNUNG

## DETAILZEICHNUNG OVALES BECKEN IV (11,7 x 5,70)

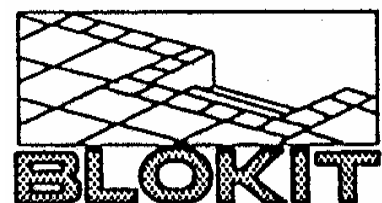

ZEICHNUNG B 123

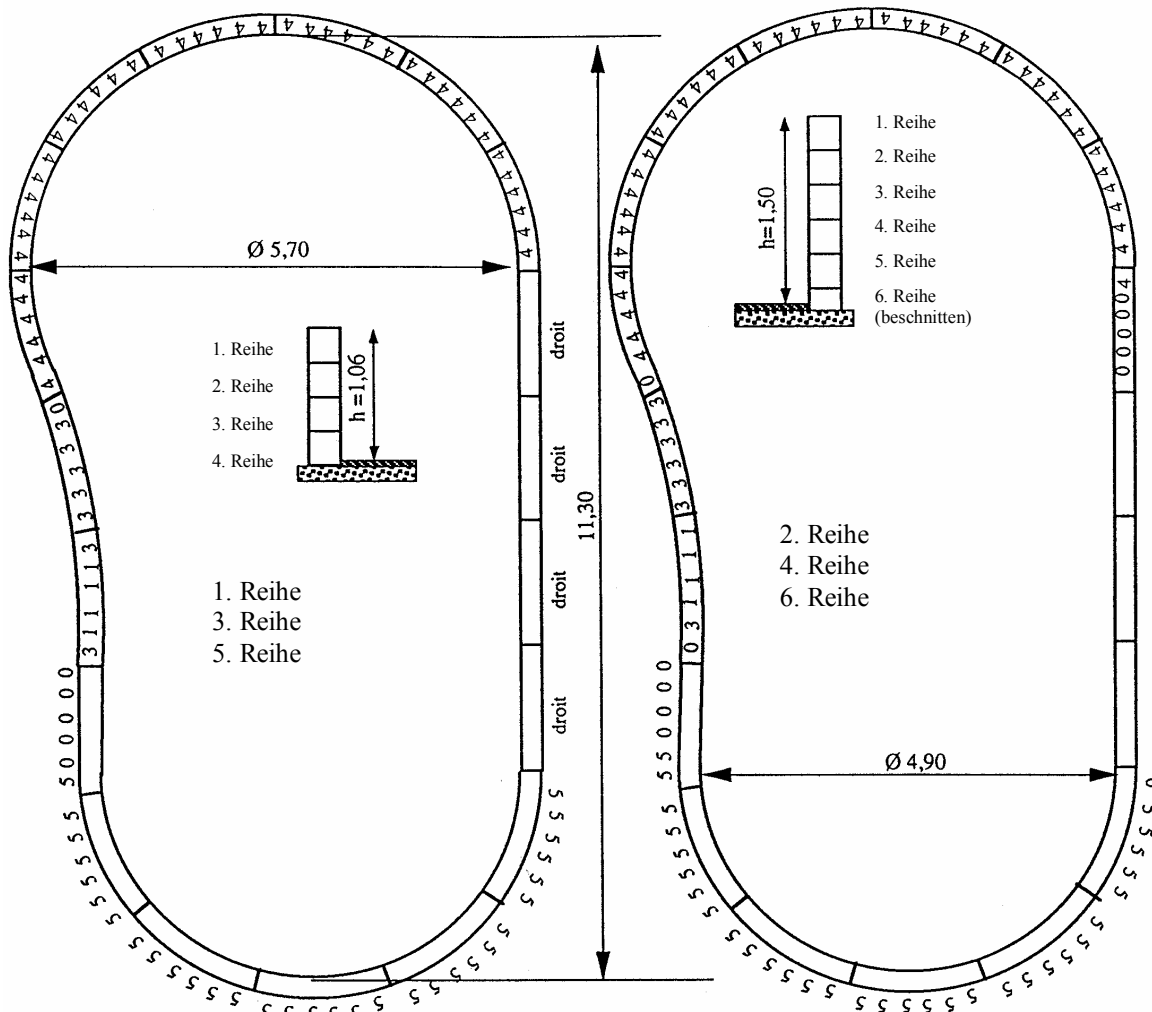
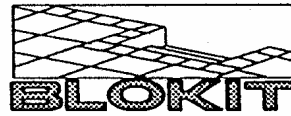

		Pyramidenstumpf	Flacher Untergrund 150
3310200	Blokkit mit Öffnung 1,50 m	62	77
3300200	Blokkit 1,50 m	14	18
3320200	Blokkit mit Öffnung 1,50 beschnitten	-	16
3320200	Blokkit 1,50 beschnitten		3
3341200	Stopper Nr. 0	36	54
3341400	Stopper Nr. 1	16	24
3318000	Stopper Nr. 3	28	42
3342000	Stopper Nr. 4	168	254
3342200	Stopper Nr. 5	124	186
3350200	Hung gerade(m)	6	6
3350800	Hung gebogen (m)	23	23
3360200	Polyester 1,04 x 1,34	22	-
3360400	Polyester 1,48 x 1,34	-	22
3360900	Kleber für Hülle	3	3
3360600	Schutzhülle außen, H=1,34	33	-
3360700	Schutzhülle außen, H=1,70	-	33

# TECHNISCHE ZEICHNUNG

## DETAILZEICHNUNG NIERENFÖRMIGES BECKEN KIDNEY I

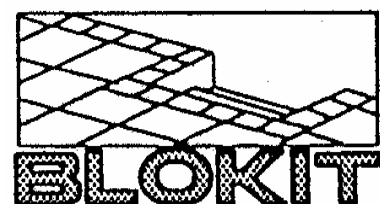

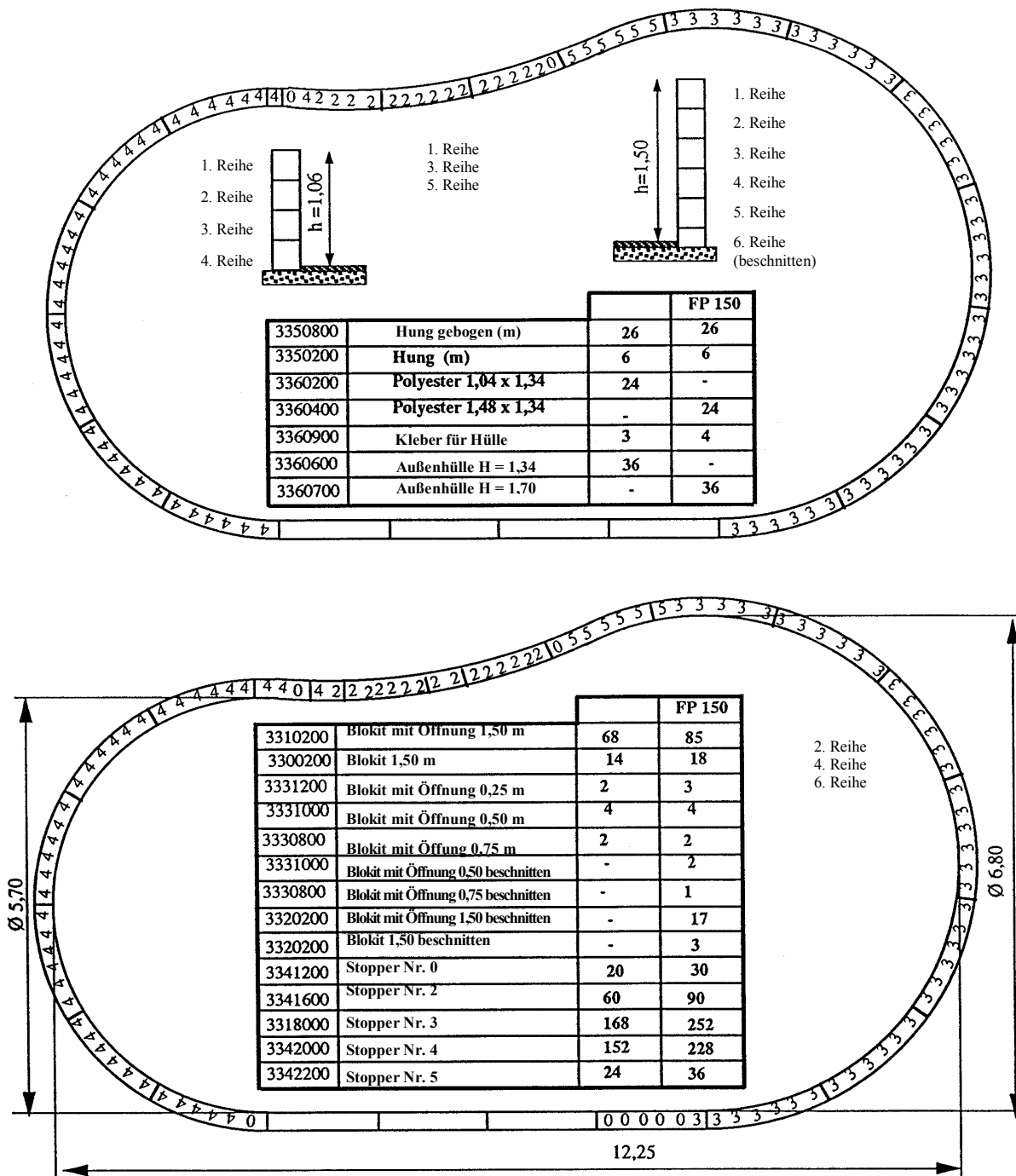
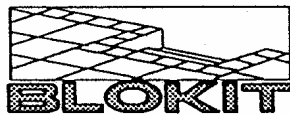

# TECHNISCHE ZEICHNUNG

## DETAILZEICHNUNG NIERENFÖRMIGES BECKEN KIDNEY II

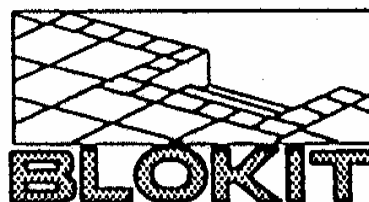

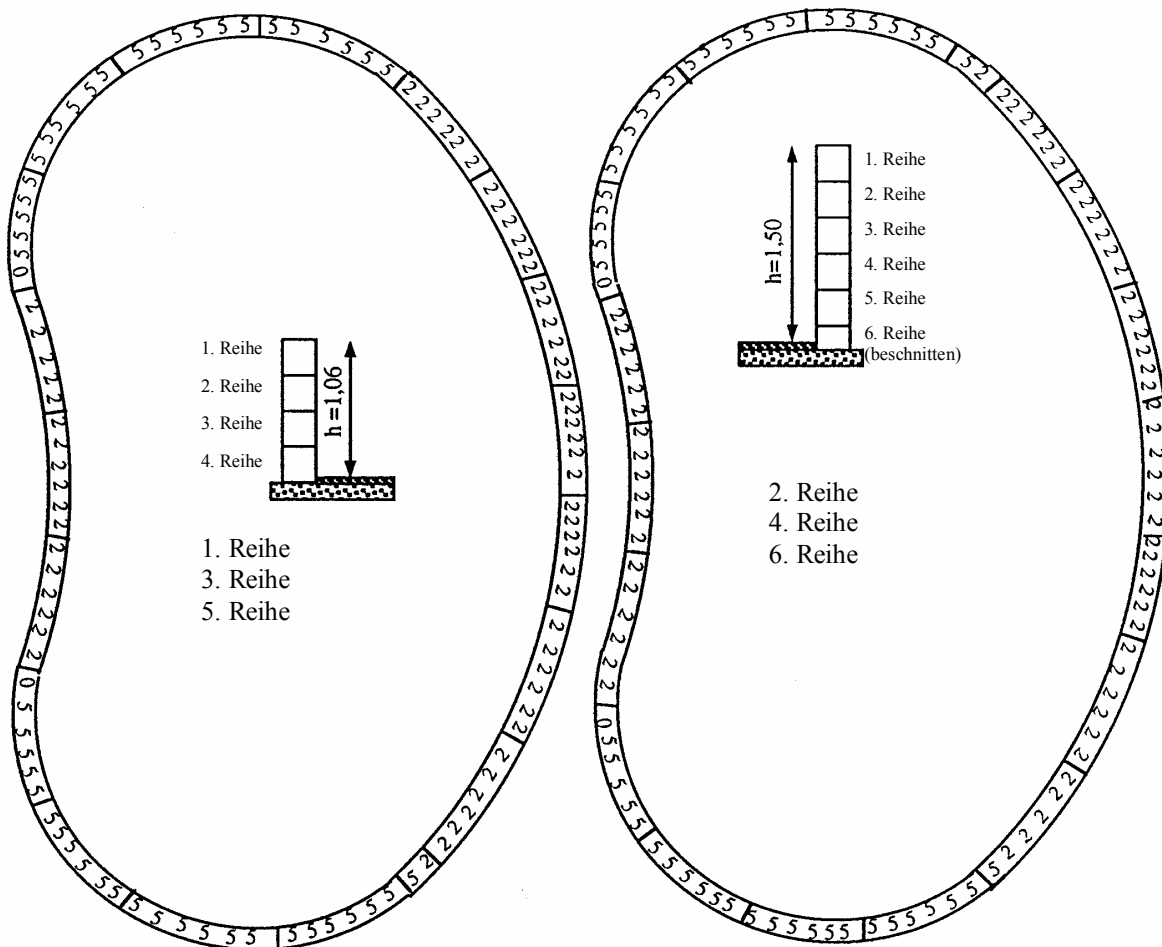
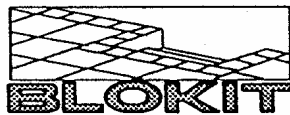

		Pyramidenstumpf	Flacher Untergrund150
3310200	Blokit mit Öffnung 1,50 m	72	90
3310200	Blokit mit Öffnung 0,50 m	4	5
3320200	Blokit mit Öffnung 1,50 beschnitten	-	18
3330200	Blokit mit Öffnung 0,50 beschnitten	-	1
3341200	Stopper Nr. 0	8	12
3341600	Stopper Nr. 2	242	363
3342200	Stopper Nr. 5	190	285
3350800	Hung gebogen (m)	28	28
3360200	Polyester 1,04 x 1,34	21	-
3360400	Polyester 1,48 x 1,34	-	21
3360900	Kleber für Hülle	3	3
3360600	Schutzhülle außen, H=1,34	31	-
3360700	Schutzhülle außen, H=1,70	-	31

# TECHNISCHE ZEICHNUNG

## DETAILZEICHNUNG HARICOT I

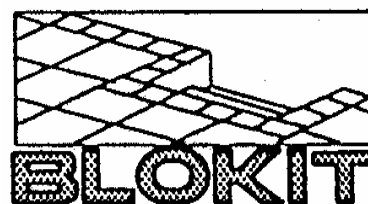

ZEICHNUNG B 135

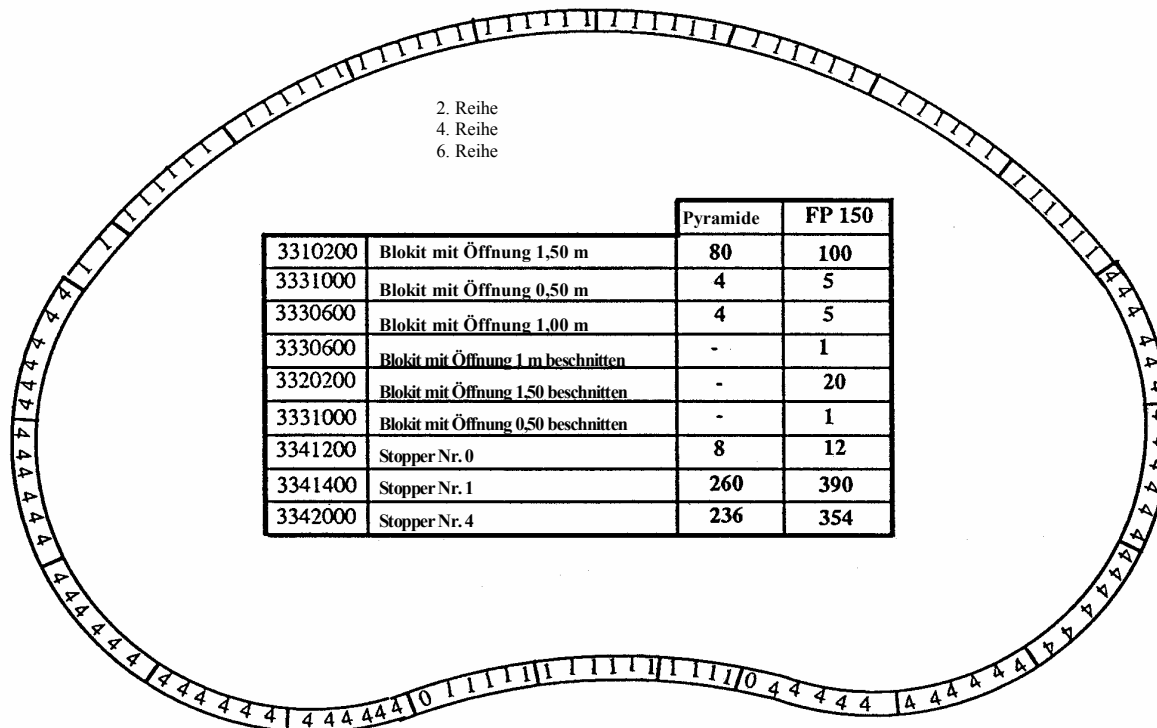
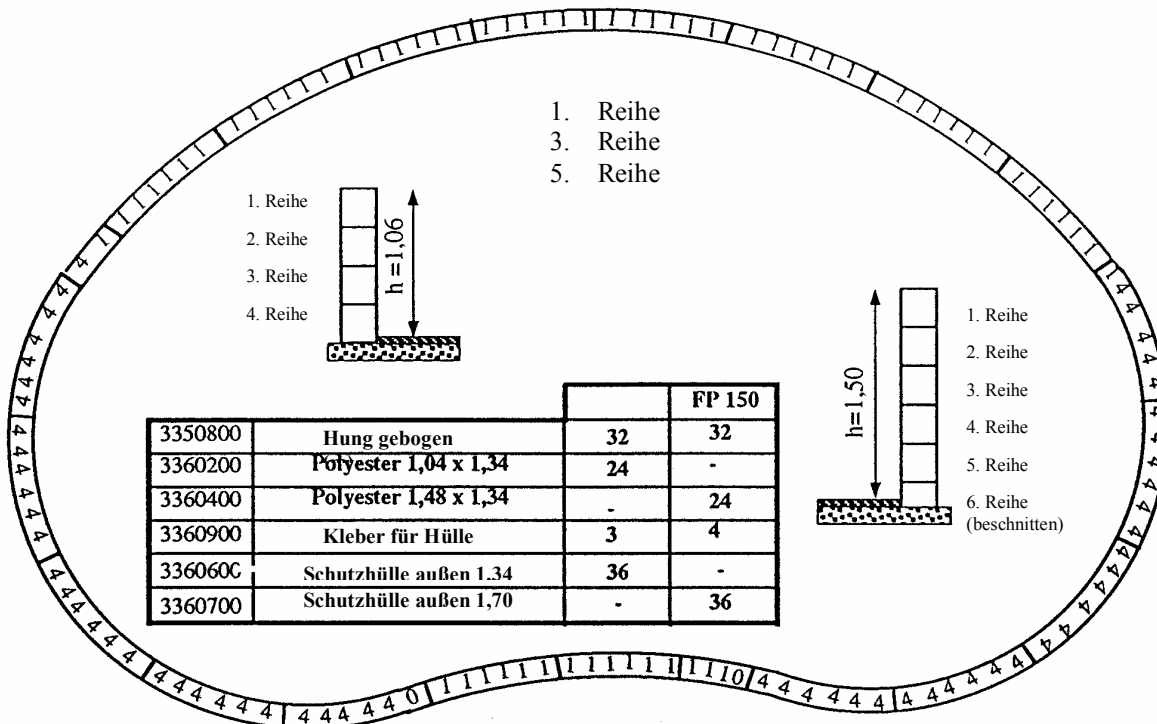
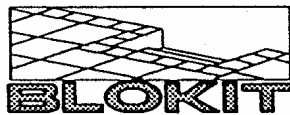

# TECHNISCHE ZEICHNUNG

## DETAILZEICHNUNG HARICOT II

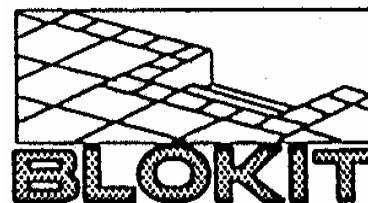

ZEICHNUNG B 136

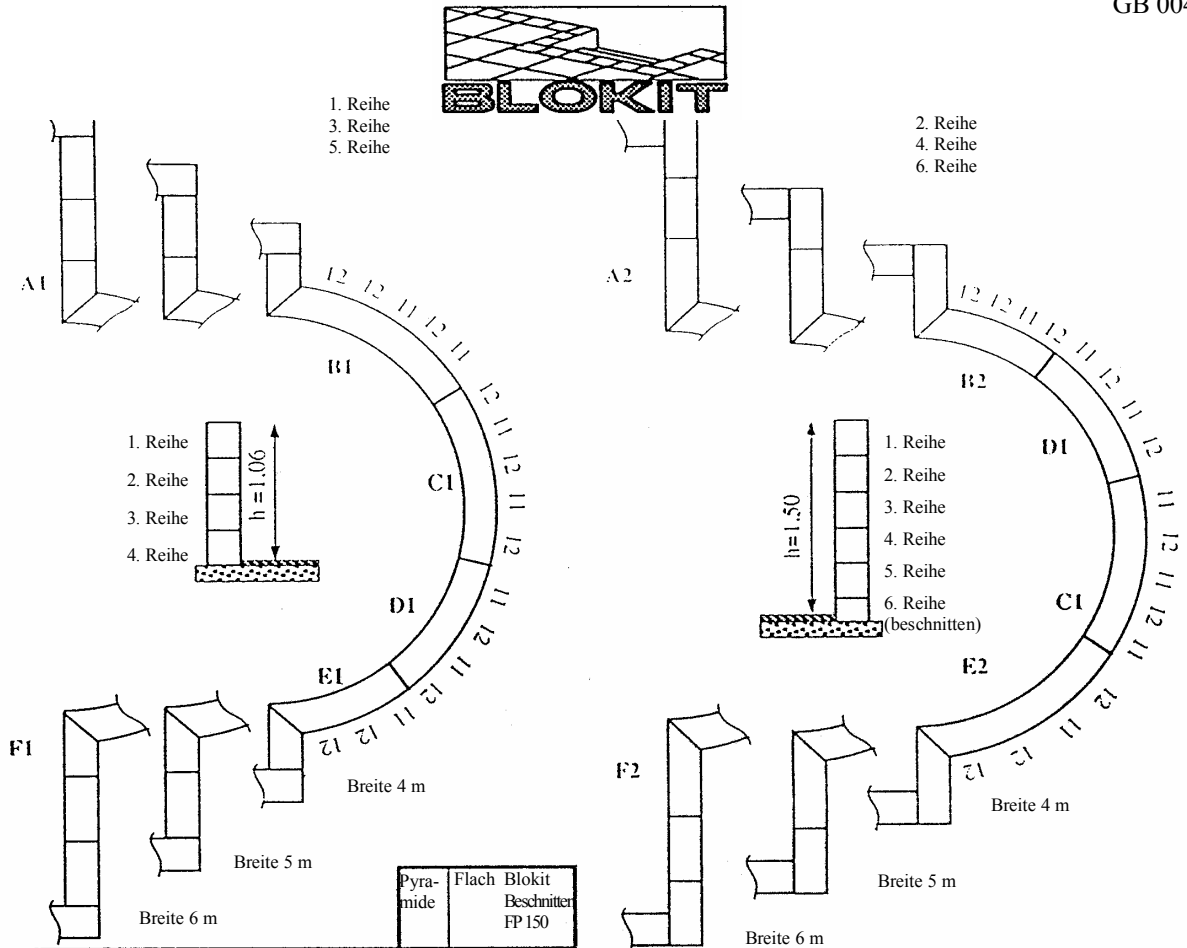

	Pyra- mide	Flach Blokit Beschnitt FP 150
Blokit 0,50 m für 4 m Breite	-4	-6
" 5 m Breite	2	3
" 6 m Breite	14	21
Blokit 1,50 m für 4 m Breite	-10	-15
" 5 m Breite	-12	-18
" 6 m Breite	-16	-24

	Pyra- mide	Flach Blokit Beschnitt FP 150
Stopper Nr. 11	28	42
Stopper Nr. 12	40	60
Blokit A1	2	3
Blokit A2	2	2
Blokit F1	2	3
Blokit F2	2	2
Blokit B1 (Öffnung)	2	3
Blokit B2 (Öffnung)	2	2
Blokit C1 (Öffnung)	4	5
Blokit D1 (Öffnung)	4	5
Blokit E2 (Öffnung)	2	2
Blokit E1 (Öffnung)	2	3

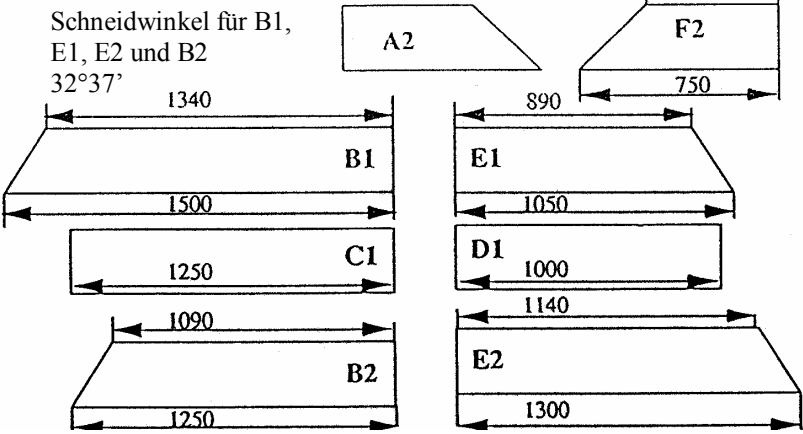

# TECHNISCHE ZEICHNUNG

## RÖMISCHE STRUKTUR

3 m

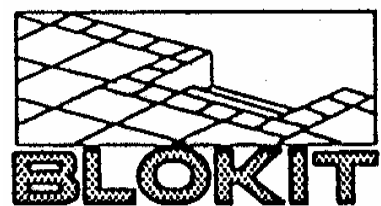

ZEICHNUNG B 140



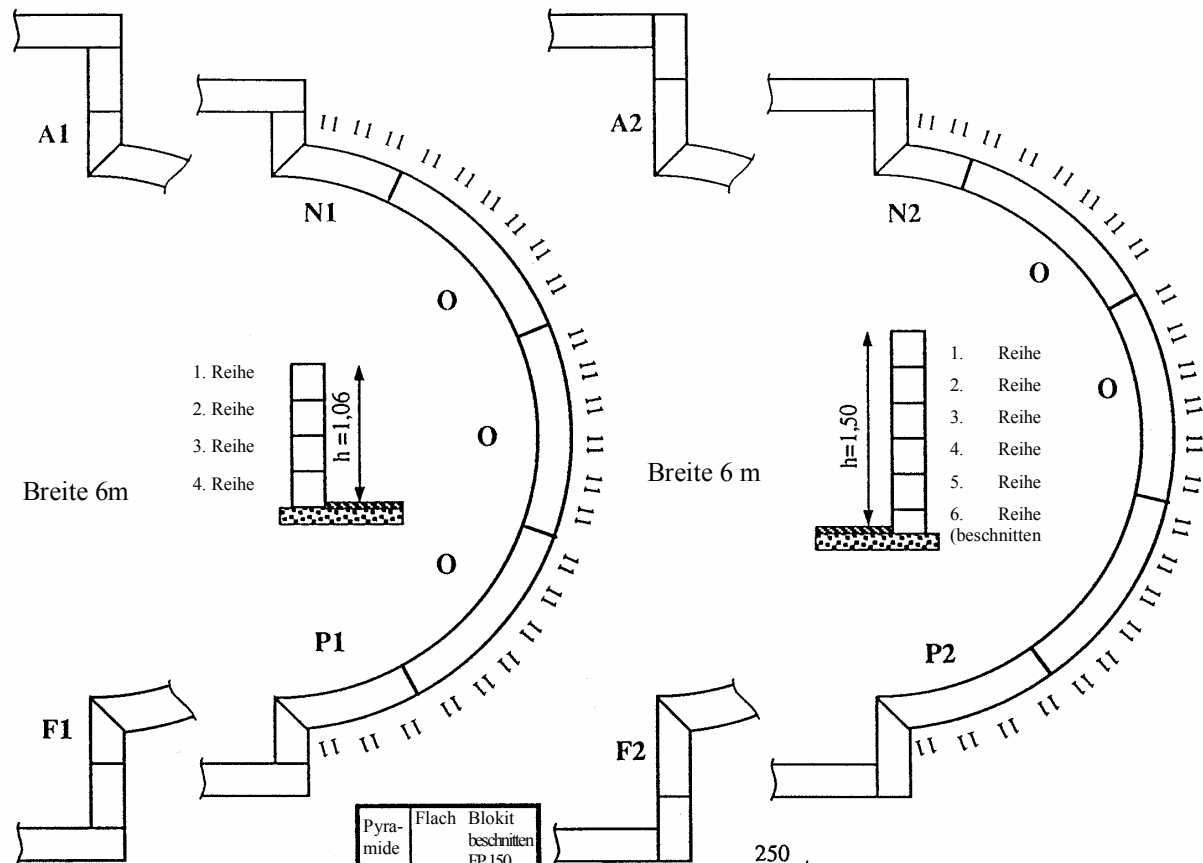
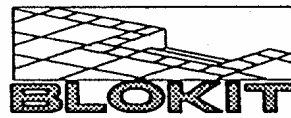

	Pyra- mide	Flach Blokkit beschnitten FP 150
Blokkit 0,50 m für 5 m Breite	-6	9
Blokkit 0,50 m für 6 m Breite	6	9
Blokkit 1,50 m für 5 m Breite	-12	-18
Blokkit 1,50 m für 6 m Breite	-16	-24

	Pyra- mide	Flach Blokkit beschnitten FP 150
Stopper Nr. 11	96	144
Blokkit A1	2	3
Blokkit A2	2	2
Blokkit F1	2	3
Blokkit F2	2	2
Blokkit N1 (Öffnung)	2	3
Blokkit N2 (Öffnung)	2	2
Blokkit P1 (Öffnung)	2	3
Blokkit P2 (Öffnung)	2	2
Blokkit 0	12	15

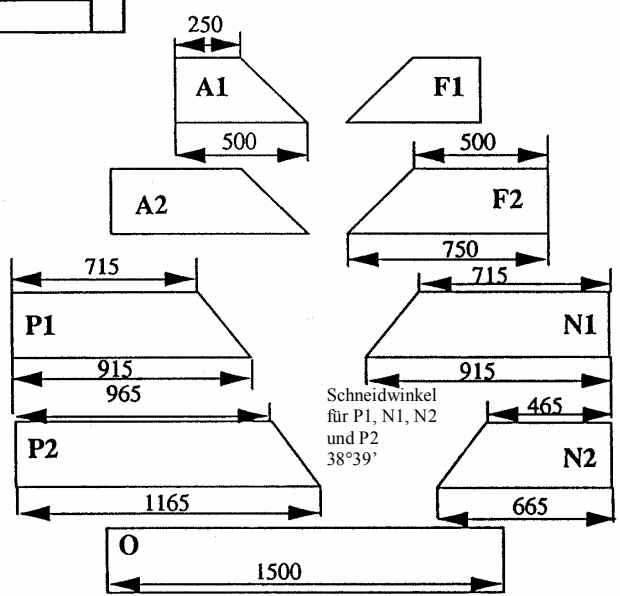

Schneidwinkel  
für P1, N1, N2  
und P2  
38°39'



**MYPOOLDIRECT**  
Swimming Pool & Enclosure European Distributor

UK SALES OFFICE: +44 (0) 1268 710425